

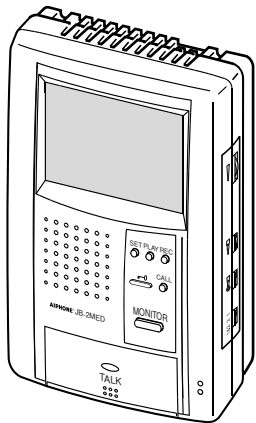

# JB-2MED, JB-2MD, JB-2HD

HANDSFREE COLOR VIDEO INTERCOM  
 HANDSFREE COLOR VIDEO INTERCOM  
 HANDSFREE COLOR VIDEO INTERCOM  
 HANDSFREE COLOR VIDEO INTERCOM  
 HANDSFREE COLOR VIDEO INTERCOM



## JB-2MED

Master monitor station (w/ built-in picture memory)  
 Master monitor station (w/ built-in picture memory)  
 Master monitor station (w/ built-in picture memory)  
 Master monitor station (w/ built-in picture memory)  
 Master monitor station (w/ built-in picture memory)

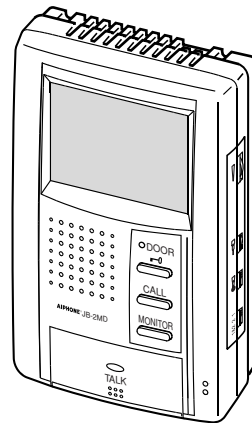

## JB-2MD

Master monitor station  
 Master monitor station  
 Master monitor station  
 Master monitor station  
 Master monitor station

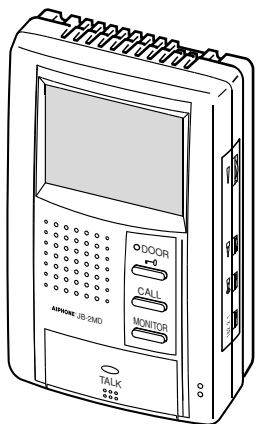





## JB-2HD

Sub monitor station  
 Sub monitor station  
 Sub monitor station  
 Sub monitor station  
 Sub monitor station

INSTALLATION & OPERATION MANUAL  
 INSTALLATION & OPERATION MANUAL  
 INSTALLATION & OPERATION MANUAL  
 INSTALLATION & OPERATION MANUAL  
 INSTALLATION & OPERATION MANUAL









## PRECAUTIONS

English

-  General Prohibitions
-  Prohibitions on Dismantling the Unit
-  Prohibitions on Subjecting the Unit to Water
-  General Precautions







### WARNING

*(Negligence could result in death or serious injury to people)*

-  1. High voltage is present internally. Do not open the case. Electric shock could result.
-  2. Do not dismantle or alter the unit. Fire or electric shock could result.
-  3. Do not connect any power source other than specified to terminals +, -, nor install 2 power supplies in parallel to single input. Fire or unit damage could result.
-  4. Keep the unit away from water or any other liquid. Fire or electric shock could result.
-  5. Do not put any metal into the unit through the openings. Fire or electric shock could result.
-  6. When existing chime wiring is used, it is possible that it contains AC power. Unit damage or electric shock could result. Ask a qualified electrician.
-  7. Do not puncture the LCD panel with a sharp-edged tool. Damage to the LCD panel could occur, causing a liquid crystal spill. If liquid crystal makes contact with the eyes or mouth, immediately wash away with water.
-  8. Do not subject the monitor of the video entry security system to pressure. If fractured, injury could result.
-  9. Do not use a power supply with a voltage other than specified. Fire or electric shock could result.

### CAUTION

*(Negligence could result in injury to people or damage to property)*





-  1. Before turning on the power, make sure wires are not crossed or shorted. Fire or electric shock could result.
-  2. Mount the unit onto the wall in a place where it cannot be easily jarred or bumped by people. Injury could result.
-  3. Do not make any wiring connections while the power supply is turned on. Electric shock or unit trouble could result.
-  4. Do not install or use the unit in any of the following places. · Places in direct sunlight, or near heating equipment that varies in temperature. · Places subject to metal particles, dust, oil, chemicals. · Places subject to moisture and humidity extremes, such as bathrooms, cellars, greenhouses, etc. · Places where the temperature is quite low, such as inside a refrigerated area or in front of an air-conditioner.
-  5. Do not cover the unit with a cloth, etc. Fire or unit trouble could result.
-  6. Use Aiphone Power Supply or specified one by Aiphone. If not used, it may be a possible cause of fire or malfunction.

## GENERAL PRECAUTIONS

1. This unit is for indoor use only. Do not use outdoors.
2. When wall-mounted, the unit may become black and sooty. This does not indicate unit trouble.
3. In areas where broadcasting station antennas are close by, the intercom system may be affected by radio frequency interference.
4. The unit may become a little warm with use, but this is not a malfunction.
5. If a cellular phone is used close by, the unit may malfunction.
6. It must be noted in advance that the LCD panel, though manufactured with very high precision techniques, inevitably will have a very small portion of its picture elements always lit or not lit at all. This is not considered a unit malfunction.
7. Keep the unit more than 1 m away from radio or TV sets.
8. If the monitor station is operated near office equipment, radios or TVs, it will be affected by radio wave interference or noise. Carefully select the place of use.
9. Ambient noise around the unit may prevent normal communication. This is not unit trouble.
10. As to other manufacturer's devices, such as sensor, used with this system, comply with the relative specifications and warranty conditions of the devices.







## PRECAUTIONS



Français

-  General Prohibitions
-  Prohibitions on Dismantling the Unit
-  Prohibitions on Subjecting the Unit to Water
-  General Precautions

### WARNING







*(Negligence could result in death or serious injury to people)*

-  1. High voltage is present internally. Do not open the case. Electric shock could result.
-  2. Do not dismantle or alter the unit. Fire or electric shock could result.
-  3. Do not connect any power source other than specified to terminals +, -, nor install 2 power supplies in parallel to single input. Fire or unit damage could result.
-  4. Keep the unit away from water or any other liquid. Fire or electric shock could result.
-  5. Do not put any metal into the unit through the openings. Fire or electric shock could result.
-  6. When existing chime wiring is used, it is possible that it contains AC power. Unit damage or electric shock could result. Ask a qualified electrician.

-  7. Do not puncture the LCD panel with a sharp-edged tool. Damage to the LCD panel could occur, causing a liquid crystal spill. If liquid crystal makes contact with the eyes or mouth, immediately wash away with water.
-  8. Do not subject the monitor of the video entry security system to pressure. If fractured, injury could result.
-  9. Do not use a power supply with a voltage other than specified. Fire or electric shock could result.

### CAUTION

*(Negligence could result in injury to people or damage to property)*





-  1. Before turning on the power, make sure wires are not crossed or shorted. Fire or electric shock could result.
-  2. Mount the unit onto the wall in a place where it cannot be easily jarred or bumped by people. Injury could result.
-  3. Do not make any wiring connections while the power supply is turned on. Electric shock or unit trouble could result.
-  4. Do not install or use the unit in any of the following places. · Places in direct sunlight, or near heating equipment that varies in temperature. · Places subject to metal particles, dust, oil, chemicals. · Places subject to moisture and humidity extremes, such as bathrooms, cellars, greenhouses, etc. · Places where the temperature is quite low, such as inside a refrigerated area or in front of an air-conditioner.
-  5. Do not cover the unit with a cloth, etc. Fire or unit trouble could result.
-  6. Use Aiphone Power Supply or specified one by Aiphone. If not used, it may be a possible cause of fire or malfunction.

## GENERAL PRECAUTIONS

1. This unit is for indoor use only. Do not use outdoors.
2. When wall-mounted, the unit may become black and sooty. This does not indicate unit trouble.
3. In areas where broadcasting station antennas are close by, the intercom system may be affected by radio frequency interference.
4. The unit may become a little warm with use, but this is not a malfunction.
5. If a cellular phone is used close by, the unit may malfunction.
6. It must be noted in advance that the LCD panel, though manufactured with very high precision techniques, inevitably will have a very small portion of its picture elements always lit or not lit at all. This is not considered a unit malfunction.
7. Keep the unit more than 1 m away from radio or TV sets.
8. If the monitor station is operated near office equipment, radios or TVs, it will be affected by radio wave interference or noise. Carefully select the place of use.
9. Ambient noise around the unit may prevent normal communication. This is not unit trouble.
10. As to other manufacturer's devices, such as sensor, used with this system, comply with the relative specifications and warranty conditions of the devices.









## PRECAUTIONS

Deutsch

-  General Prohibitions
-  Prohibitions on Dismantling the Unit
-  Prohibitions on Subjecting the Unit to Water
-  General Precautions





### WARNING

*(Negligence could result in death or serious injury to people)*

-  1. High voltage is present internally. Do not open the case. Electric shock could result.
-  2. Do not dismantle or alter the unit. Fire or electric shock could result.
-  3. Do not connect any power source other than specified to terminals +, -, nor install 2 power supplies in parallel to single input. Fire or unit damage could result.
-  4. Keep the unit away from water or any other liquid. Fire or electric shock could result.
-  5. Do not put any metal into the unit through the openings. Fire or electric shock could result.
-  6. When existing chime wiring is used, it is possible that it contains AC power. Unit damage or electric shock could result. Ask a qualified electrician.
-  7. Do not puncture the LCD panel with a sharp-edged tool. Damage to the LCD panel could occur, causing a liquid crystal spill. If liquid crystal makes contact with the eyes or mouth, immediately wash away with water.
-  8. Do not subject the monitor of the video entry security system to pressure. If fractured, injury could result.
-  9. Do not use a power supply with a voltage other than specified. Fire or electric shock could result.

### CAUTION

*(Negligence could result in injury to people or damage to property)*

-  1. Before turning on the power, make sure wires are not crossed or shorted. Fire or electric shock could result.
-  2. Mount the unit onto the wall in a place where it cannot be easily jarred or bumped by people. Injury could result.
-  3. Do not make any wiring connections while the power supply is turned on. Electric shock or unit trouble could result.
-  4. Do not install or use the unit in any of the following places. · Places in direct sunlight, or near heating equipment that varies in temperature. · Places subject to metal particles, dust, oil, chemicals. · Places subject to moisture and humidity extremes, such as bathrooms, cellars, greenhouses, etc. · Places where the temperature is quite low, such as inside a refrigerated area or in front of an air-conditioner.

- 5. Do not cover the unit with a cloth, etc. Fire or unit trouble could result.
- 6. Use Aiphone Power Supply or specified one by Aiphone. If not used, it may be a possible cause of fire or malfunction.

## GENERAL PRECAUTIONS

1. This unit is for indoor use only. Do not use outdoors.
2. When wall-mounted, the unit may become black and sooty. This does not indicate unit trouble.
3. In areas where broadcasting station antennas are close by, the intercom system may be affected by radio frequency interference.
4. The unit may become a little warm with use, but this is not a malfunction.
5. If a cellular phone is used close by, the unit may malfunction.
6. It must be noted in advance that the LCD panel, though manufactured with very high precision techniques, inevitably will have a very small portion of its picture elements always lit or not lit at all. This is not considered a unit malfunction.
7. Keep the unit more than 1 m away from radio or TV sets.
8. If the monitor station is operated near office equipment, radios or TVs, it will be affected by radio wave interference or noise. Carefully select the place of use.
9. Ambient noise around the unit may prevent normal communication. This is not unit trouble.
10. As to other manufacturer's devices, such as sensor, used with this system, comply with the relative specifications and warranty conditions of the devices.

## PRECAUTIONS

Español

- General Prohibitions
- Prohibitions on Dismantling the Unit
- Prohibitions on Subjecting the Unit to Water
- General Precautions

### ⚠ WARNING

*(Negligence could result in death or serious injury to people)*

- 1. High voltage is present internally. Do not open the case. Electric shock could result.
- 2. Do not dismantle or alter the unit. Fire or electric shock could result.
- 3. Do not connect any power source other than specified to terminals +, -, nor install 2 power supplies in parallel to single input. Fire or unit damage could result.
- 4. Keep the unit away from water or any other liquid. Fire or electric shock could result.
- 5. Do not put any metal into the unit through the openings. Fire or electric shock could result.
- 6. When existing chime wiring is used, it is possible that it contains AC power. Unit damage or electric shock could result. Ask a qualified electrician.
- 7. Do not puncture the LCD panel with a sharp-edged tool. Damage to the LCD panel could occur, causing a liquid crystal spill. If liquid crystal makes contact with the eyes or mouth, immediately wash away with water.
- 8. Do not subject the monitor of the video entry security system to pressure. If fractured, injury could result.
- 9. Do not use a power supply with a voltage other than specified. Fire or electric shock could result.

### ⚠ CAUTION

*(Negligence could result in injury to people or damage to property)*

- 1. Before turning on the power, make sure wires are not crossed or shorted. Fire or electric shock could result.
- 2. Mount the unit onto the wall in a place where it cannot be easily jarred or bumped by people. Injury could result.
- 3. Do not make any wiring connections while the power supply is turned on. Electric shock or unit trouble could result.
- 4. Do not install or use the unit in any of the following places. · Places in direct sunlight, or near heating equipment that varies in temperature. · Places subject to metal particles, dust, oil, chemicals. · Places subject to moisture and humidity extremes, such as bathrooms, cellars, greenhouses, etc. · Places where the temperature is quite low, such as inside a refrigerated area or in front of an air-conditioner.
- 5. Do not cover the unit with a cloth, etc. Fire or unit trouble could result.
- 6. Use Aiphone Power Supply or specified one by Aiphone. If not used, it may be a possible cause of fire or malfunction.

## GENERAL PRECAUTIONS

1. This unit is for indoor use only. Do not use outdoors.
2. When wall-mounted, the unit may become black and sooty. This does not indicate unit trouble.
3. In areas where broadcasting station antennas are close by, the intercom system may be affected by radio frequency interference.
4. The unit may become a little warm with use, but this is not a malfunction.
5. If a cellular phone is used close by, the unit may malfunction.
6. It must be noted in advance that the LCD panel, though manufactured with very high precision techniques, inevitably will have a very small portion of its picture elements always lit or not lit at all. This is not considered a unit malfunction.
7. Keep the unit more than 1 m away from radio or TV sets.
8. If the monitor station is operated near office equipment, radios or TVs, it will be affected by radio wave interference or noise. Carefully select the place of use.
9. Ambient noise around the unit may prevent normal communication. This is not unit trouble.
10. As to other manufacturer's devices, such as sensor, used with this system, comply with the relative specifications and warranty conditions of the devices.

## PRECAUTIONS

Nederlands

- General Prohibitions
- Prohibitions on Dismantling the Unit
- Prohibitions on Subjecting the Unit to Water
- General Precautions

### ⚠ WARNING

*(Negligence could result in death or serious injury to people)*

- 1. High voltage is present internally. Do not open the case. Electric shock could result.
- 2. Do not dismantle or alter the unit. Fire or electric shock could result.
- 3. Do not connect any power source other than specified to terminals +, -, nor install 2 power supplies in parallel to single input. Fire or unit damage could result.
- 4. Keep the unit away from water or any other liquid. Fire or electric shock could result.
- 5. Do not put any metal into the unit through the openings. Fire or electric shock could result.
- 6. When existing chime wiring is used, it is possible that it contains AC power. Unit damage or electric shock could result. Ask a qualified electrician.
- 7. Do not puncture the LCD panel with a sharp-edged tool. Damage to the LCD panel could occur, causing a liquid crystal spill. If liquid crystal makes contact with the eyes or mouth, immediately wash away with water.
- 8. Do not subject the monitor of the video entry security system to pressure. If fractured, injury could result.
- 9. Do not use a power supply with a voltage other than specified. Fire or electric shock could result.

### ⚠ CAUTION

*(Negligence could result in injury to people or damage to property)*

- 1. Before turning on the power, make sure wires are not crossed or shorted. Fire or electric shock could result.
- 2. Mount the unit onto the wall in a place where it cannot be easily jarred or bumped by people. Injury could result.
- 3. Do not make any wiring connections while the power supply is turned on. Electric shock or unit trouble could result.
- 4. Do not install or use the unit in any of the following places. · Places in direct sunlight, or near heating equipment that varies in temperature. · Places subject to metal particles, dust, oil, chemicals. · Places subject to moisture and humidity extremes, such as bathrooms, cellars, greenhouses, etc. · Places where the temperature is quite low, such as inside a refrigerated area or in front of an air-conditioner.
- 5. Do not cover the unit with a cloth, etc. Fire or unit trouble could result.
- 6. Use Aiphone Power Supply or specified one by Aiphone. If not used, it may be a possible cause of fire or malfunction.

## GENERAL PRECAUTIONS

1. This unit is for indoor use only. Do not use outdoors.
2. When wall-mounted, the unit may become black and sooty. This does not indicate unit trouble.
3. In areas where broadcasting station antennas are close by, the intercom system may be affected by radio frequency interference.
4. The unit may become a little warm with use, but this is not a malfunction.
5. If a cellular phone is used close by, the unit may malfunction.
6. It must be noted in advance that the LCD panel, though manufactured with very high precision techniques, inevitably will have a very small portion of its picture elements always lit or not lit at all. This is not considered a unit malfunction.
7. Keep the unit more than 1 m away from radio or TV sets.
8. If the monitor station is operated near office equipment, radios or TVs, it will be affected by radio wave interference or noise. Carefully select the place of use.
9. Ambient noise around the unit may prevent normal communication. This is not unit trouble.
10. As to other manufacturer's devices, such as sensor, used with this system, comply with the relative specifications and warranty conditions of the devices.

# 1 PACKAGE CONTENTS

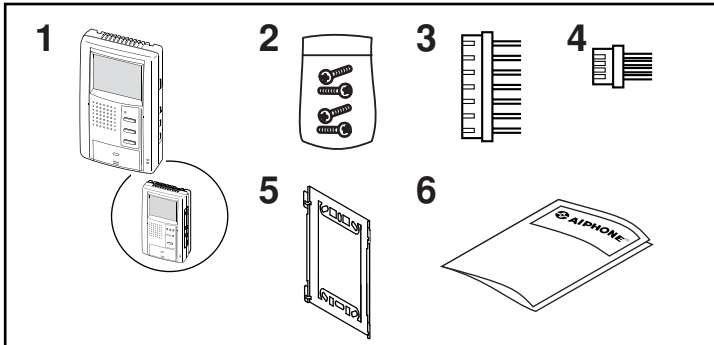

**Package contents** English

1. JB-2MD or JB-2MED or JB-2HD
2. Packet of screws
3. Connector for optional features
4. Door release connector (JB-2MD or JB-2MED only)
5. Mounting bracket
6. INSTALLATION & OPERATION MANUAL

**Package contents** Français

1. JB-2MD or JB-2MED or JB-2HD
2. Packet of screws
3. Connector for optional features
4. Door release connector (JB-2MD or JB-2MED only)
5. Mounting bracket
6. INSTALLATION & OPERATION MANUAL

**Package contents** Deutsch

1. JB-2MD or JB-2MED or JB-2HD
2. Packet of screws
3. Connector for optional features
4. Door release connector (JB-2MD or JB-2MED only)
5. Mounting bracket
6. INSTALLATION & OPERATION MANUAL

**Package contents** Español

1. JB-2MD or JB-2MED or JB-2HD
2. Packet of screws
3. Connector for optional features
4. Door release connector (JB-2MD or JB-2MED only)
5. Mounting bracket
6. INSTALLATION & OPERATION MANUAL

**Package contents** Nederlands

1. JB-2MD or JB-2MED or JB-2HD
2. Packet of screws
3. Connector for optional features
4. Door release connector (JB-2MD or JB-2MED only)
5. Mounting bracket
6. INSTALLATION & OPERATION MANUAL

# 2 INSTALLATION

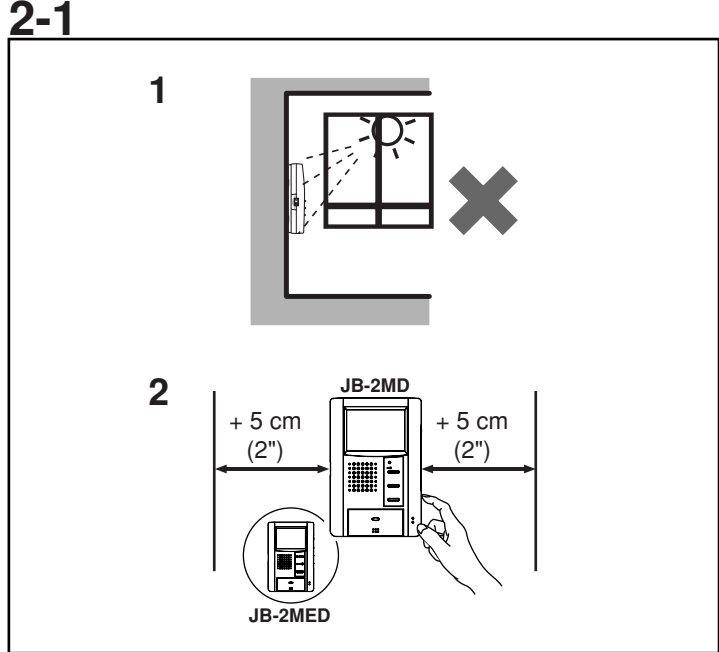

**Installation locations** English

1. Install the master monitor station in a place where the screen is not exposed to direct sunlight.
2. The master monitor station has manual adjustment switches on both sides. Secure an open space of 5 cm (2") on either side of the monitor.

**Installation locations** Français

1. Install the master monitor station in a place where the screen is not exposed to direct sunlight.
2. The master monitor station has manual adjustment switches on both sides. Secure an open space of 5 cm (2") on either side of the monitor.

**Installation locations** Deutsch

1. Install the master monitor station in a place where the screen is not exposed to direct sunlight.
2. The master monitor station has manual adjustment switches on both sides. Secure an open space of 5 cm (2") on either side of the monitor.

**Installation locations** Español

1. Install the master monitor station in a place where the screen is not exposed to direct sunlight.
2. The master monitor station has manual adjustment switches on both sides. Secure an open space of 5 cm (2") on either side of the monitor.

**Installation locations** Nederlands

1. Install the master monitor station in a place where the screen is not exposed to direct sunlight.
2. The master monitor station has manual adjustment switches on both sides. Secure an open space of 5 cm (2") on either side of the monitor.



## 2-2

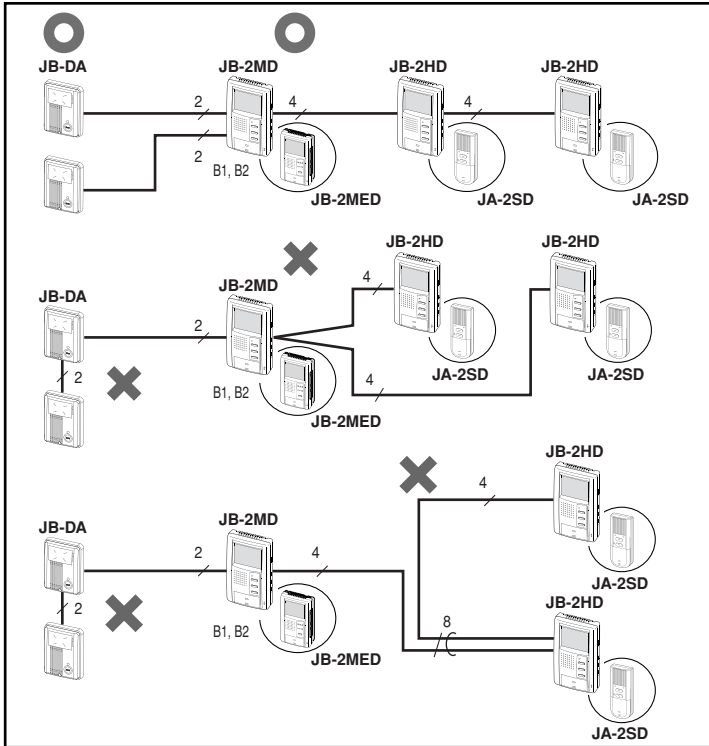

### Wiring

### English

Wire the inside stations in a daisy-chained fashion from the master to the last sub monitor.

### Wiring

### Français

Wire the inside stations in a daisy-chained fashion from the master to the last sub monitor.

### Wiring

### Deutsch

Wire the inside stations in a daisy-chained fashion from the master to the last sub monitor.

### Wiring

### Español

Wire the inside stations in a daisy-chained fashion from the master to the last sub monitor.

### Wiring

### Nederlands

Wire the inside stations in a daisy-chained fashion from the master to the last sub monitor.

## 2-3

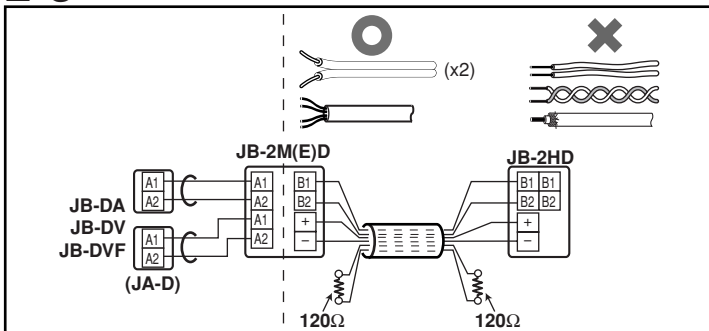

### Cable

### English

1. Parallel or jacketed 2-conductor, non-shielded cables are recommended. PVC jacket with PE (polyethylene) insulated conductors is recommended.
2. Do not use single loose wires, twisted pair cables or coaxial cables.
3. When using a cable with unused wires, it is suggested that both ends of unused pair(s) be terminated with a 120  $\Omega$  resistor.

### Cable

### Français

1. Parallel or jacketed 2-conductor, non-shielded cables are recommended. PVC jacket with PE (polyethylene) insulated conductors is recommended.
2. Do not use single loose wires, twisted pair cables or coaxial cables.

3. When using a cable with unused wires, it is suggested that both ends of unused pair(s) be terminated with a 120  $\Omega$  resistor.

### Cable

### Deutsch

1. Parallel or jacketed 2-conductor, non-shielded cables are recommended. PVC jacket with PE (polyethylene) insulated conductors is recommended.
2. Do not use single loose wires, twisted pair cables or coaxial cables.
3. When using a cable with unused wires, it is suggested that both ends of unused pair(s) be terminated with a 120  $\Omega$  resistor.

### Cable

### Español

1. Parallel or jacketed 2-conductor, non-shielded cables are recommended. PVC jacket with PE (polyethylene) insulated conductors is recommended.
2. Do not use single loose wires, twisted pair cables or coaxial cables.
3. When using a cable with unused wires, it is suggested that both ends of unused pair(s) be terminated with a 120  $\Omega$  resistor.

### Cable

### Nederlands

1. Parallel or jacketed 2-conductor, non-shielded cables are recommended. PVC jacket with PE (polyethylene) insulated conductors is recommended.
2. Do not use single loose wires, twisted pair cables or coaxial cables.
3. When using a cable with unused wires, it is suggested that both ends of unused pair(s) be terminated with a 120  $\Omega$  resistor.

## 2-4

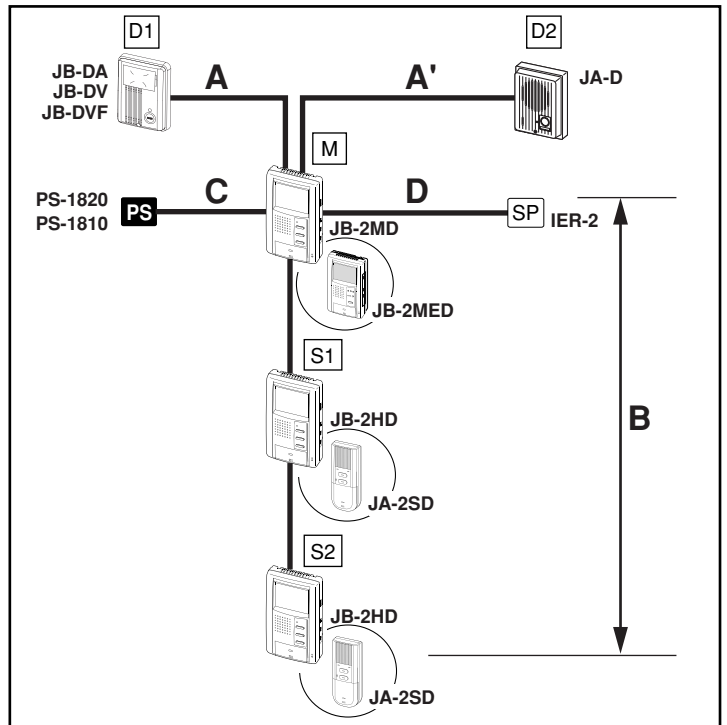

	Ø 0,65 mm	22AWG	Ø 1,0 mm	18AWG
A	50 m	165'	100 m	330'
A'	50 m	165'	100 m	330'
B	50 m	165'	100 m	330'
C	5 m	16'	10 m	33'
D	75 m	245'	150 m	490'

### Wiring distance

### English

NOTE: A Power Supply: PS-1810DIN covers 1 (or 2) Door station with One Monitor unit only. If additional Monitor(s) are to be used, please add another PS-1810DIN.

### Wiring distance

### Français

NOTE: A Power Supply: PS-1810DIN covers 1 (or 2) Door station with One Monitor unit only. If additional Monitor(s) are to be used, please add another PS-1810DIN.

**Wiring distance** **Deutsch**

NOTE: A Power Supply: PS-1810DIN covers 1(or 2) Door station with One Monitor unit only. If additional Monitor(s) are to be used, please add another PS-1810DIN.

**Wiring distance** **Español**

NOTE: A Power Supply: PS-1810DIN covers 1(or 2) Door station with One Monitor unit only. If additional Monitor(s) are to be used, please add another PS-1810DIN.

**Wiring distance** **Nederlands**

NOTE: A Power Supply: PS-1810DIN covers 1(or 2) Door station with One Monitor unit only. If additional Monitor(s) are to be used, please add another PS-1810DIN.

# 3

## MOUNTING

## MOUNTING

## MOUNTING

## MOUNTING

### 3-1

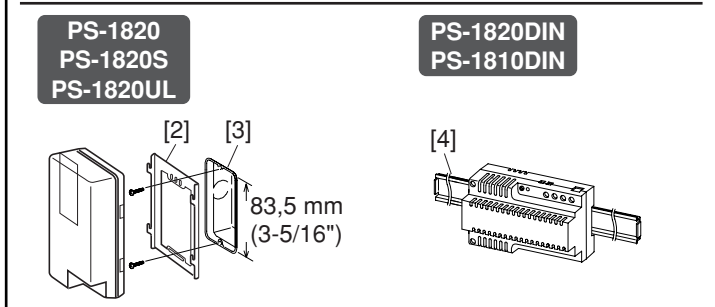
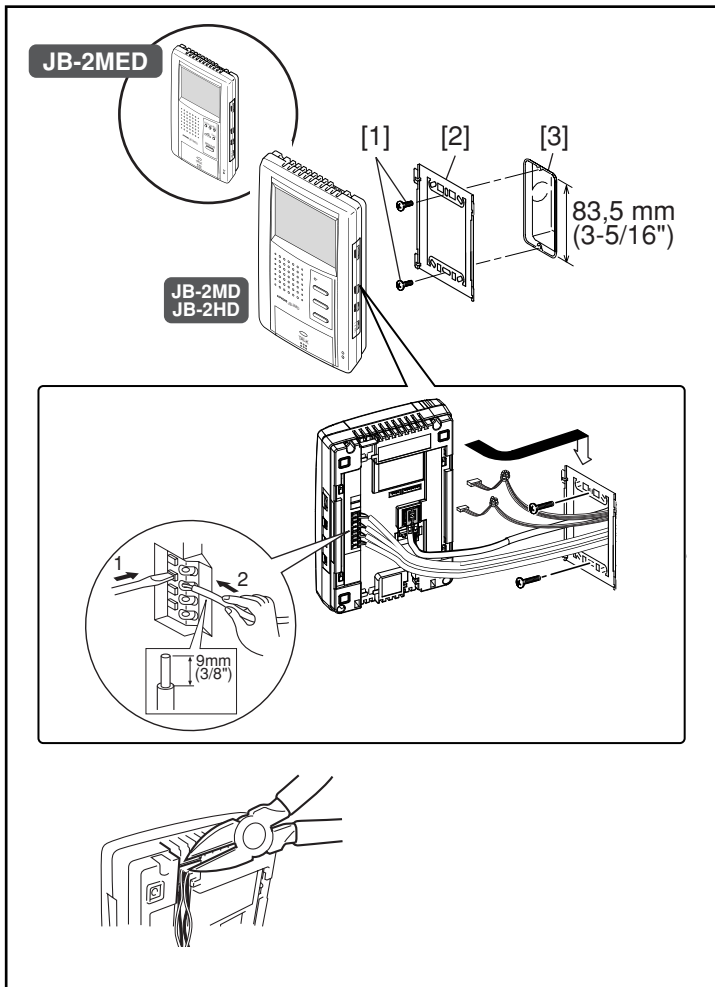

**Mounting** **English**

- [1] Screws (x2)
- [2] Mounting bracket
- [3] 1-gang box
- [4] Din rail

1. Press the RELEASE button (to insert or remove the wire).
2. Insert the cable into the terminal.

NOTES: When a 1-gang box is not installed, the cable can be surface-run to the top or bottom of the unit. Cut the cable inlet to allow passage of the wiring into the unit.

**Mounting** **Français**

- [1] Screws (x2)
- [2] Mounting bracket
- [3] 1-gang box
- [4] Din rail

1. Press the RELEASE button (to insert or remove the wire).
2. Insert the cable into the terminal.

NOTES: When a 1-gang box is not installed, the cable can be surface-run to the top or bottom of the unit. Cut the cable inlet to allow passage of the wiring into the unit.

**Mounting** **Deutsch**

- [1] Screws (x2)
- [2] Mounting bracket
- [3] 1-gang box
- [4] Din rail

1. Press the RELEASE button (to insert or remove the wire).
2. Insert the cable into the terminal.

NOTES: When a 1-gang box is not installed, the cable can be surface-run to the top or bottom of the unit. Cut the cable inlet to allow passage of the wiring into the unit.

**Mounting** **Español**

- [1] Screws (x2)
- [2] Mounting bracket
- [3] 1-gang box
- [4] Din rail

1. Press the RELEASE button (to insert or remove the wire).
2. Insert the cable into the terminal.

NOTES: When a 1-gang box is not installed, the cable can be surface-run to the top or bottom of the unit. Cut the cable inlet to allow passage of the wiring into the unit.

**Mounting** **Nederlands**

- [1] Screws (x2)
- [2] Mounting bracket
- [3] 1-gang box
- [4] Din rail

1. Press the RELEASE button (to insert or remove the wire).
2. Insert the cable into the terminal.

NOTES: When a 1-gang box is not installed, the cable can be surface-run to the top or bottom of the unit. Cut the cable inlet to allow passage of the wiring into the unit.

# 3-2

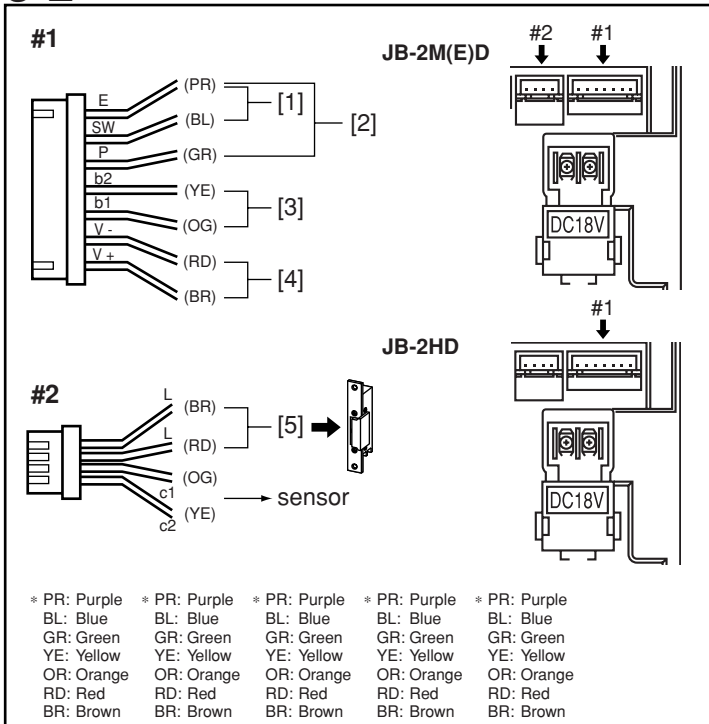

**Options** English

- [1] Foot switch  
Connect a locally available pedal foot switch to PURPLE and BLUE wires (dry closure contact).
  - [2] Manual Press-to-Talk restriction  
Short PURPLE and GREEN wires together to prevent manual TALK button operation.
  - [3] Selective door release  
Please refer to the wiring diagram #9 for detail connection.
  - [4] Video output to video monitor, video switcher, etc. (NTSC, 1 Vp-p, 75W)
  - [5] Single door release  
Connect BROWN and RED wires from connector #2 to a single door release (or to the RY-3DL as shown on the wiring diagram).
- NOTES: 1. For JB-2HD, only functions [1] and [2] are available.  
 2. Cut off unused wires and insulate the ends to prevent shorting.  
 3. Provide a box deep enough to accommodate all cables including options.

**Options** Français

- [1] Foot switch  
Connect a locally available pedal foot switch to PURPLE and BLUE wires (dry closure contact).
  - [2] Manual Press-to-Talk restriction  
Short PURPLE and GREEN wires together to prevent manual TALK button operation.
  - [3] Selective door release  
Please refer to the wiring diagram #9 for detail connection.
  - [4] Video output to video monitor, video switcher, etc. (NTSC, 1 Vp-p, 75W)
  - [5] Single door release  
Connect BROWN and RED wires from connector #2 to a single door release (or to the RY-3DL as shown on the wiring diagram).
- NOTES: 1. For JB-2HD, only functions [1] and [2] are available.  
 2. Cut off unused wires and insulate the ends to prevent shorting.  
 3. Provide a box deep enough to accommodate all cables including options.

**Options** Deutsch

- [1] Foot switch  
Connect a locally available pedal foot switch to PURPLE and BLUE wires (dry closure contact).
  - [2] Manual Press-to-Talk restriction  
Short PURPLE and GREEN wires together to prevent manual TALK button operation.
  - [3] Selective door release  
Please refer to the wiring diagram #9 for detail connection.
  - [4] Video output to video monitor, video switcher, etc. (NTSC, 1 Vp-p, 75W)
  - [5] Single door release  
Connect BROWN and RED wires from connector #2 to a single door release (or to the RY-3DL as shown on the wiring diagram).
- NOTES: 1. For JB-2HD, only functions [1] and [2] are available.  
 2. Cut off unused wires and insulate the ends to prevent shorting.  
 3. Provide a box deep enough to accommodate all cables including options.

**Options** Español

- [1] Foot switch  
Connect a locally available pedal foot switch to PURPLE and BLUE wires (dry closure contact).
  - [2] Manual Press-to-Talk restriction  
Short PURPLE and GREEN wires together to prevent manual TALK button operation.
  - [3] Selective door release  
Please refer to the wiring diagram #9 for detail connection.
  - [4] Video output to video monitor, video switcher, etc. (NTSC, 1 Vp-p, 75W)
  - [5] Single door release  
Connect BROWN and RED wires from connector #2 to a single door release (or to the RY-3DL as shown on the wiring diagram).
- NOTES: 1. For JB-2HD, only functions [1] and [2] are available.  
 2. Cut off unused wires and insulate the ends to prevent shorting.  
 3. Provide a box deep enough to accommodate all cables including options.

**Options** Nederlands

- [1] Foot switch  
Connect a locally available pedal foot switch to PURPLE and BLUE wires (dry closure contact).
  - [2] Manual Press-to-Talk restriction  
Short PURPLE and GREEN wires together to prevent manual TALK button operation.
  - [3] Selective door release  
Please refer to the wiring diagram #9 for detail connection.
  - [4] Video output to video monitor, video switcher, etc. (NTSC, 1 Vp-p, 75W)
  - [5] Single door release  
Connect BROWN and RED wires from connector #2 to a single door release (or to the RY-3DL as shown on the wiring diagram).
- NOTES: 1. For JB-2HD, only functions [1] and [2] are available.  
 2. Cut off unused wires and insulate the ends to prevent shorting.  
 3. Provide a box deep enough to accommodate all cables including options.





<b>Wiring</b>	<b>English</b>
---------------	----------------

Securely insert wires into each terminal as shown.

1. Master monitor station JB-2MD or JB-2MED
2. Sub monitor station JB-2HD or sub station JA-2SD
3. Video entrance station
4. Video or audio entrance station
5. Power supply +, - (DC 18V)
6. Optional door release EL-9S (AC 12 V, 0.35 A) or equivalent, requires a separate AC transformer. Run separate cables for the audio/video and door release.
7. Optional call extension speaker IER-2
8. Impedance matching switch Terminate farthest sub station by putting SW in ON position. Otherwise both video and audio may become distorted.
9. Optional selective door release adaptor RY-3DL Use RY-3DL when connecting a door release for 2 locations.
10. Sensor (locally available)  
Contact your local distributor for details. Use outer equipment (sensor, etc) with dry-closure contacts (CN #2 ORANGE: SG, YELLOW: 5V 11k $\Omega$ )

**NP: Non-polarized**

<b>Wiring</b>	<b>Français</b>
---------------	-----------------

Securely insert wires into each terminal as shown.

1. Master monitor station JB-2MD or JB-2MED
2. Sub monitor station JB-2HD or sub station JA-2SD
3. Video entrance station
4. Video or audio entrance station
5. Power supply +, - (DC 18V)
6. Optional door release EL-9S (AC 12 V, 0.35 A) or equivalent, requires a separate AC transformer. Run separate cables for the audio/video and door release.
7. Optional call extension speaker IER-2
8. Impedance matching switch Terminate farthest sub station by putting SW in ON position. Otherwise both video and audio may become distorted.
9. Optional selective door release adaptor RY-3DL Use RY-3DL when connecting a door release for 2 locations.
10. Sensor (locally available)  
Contact your local distributor for details. Use outer equipment (sensor, etc) with dry-closure contacts (CN #2 ORANGE: SG, YELLOW: 5V 11k $\Omega$ )

**NP: Non-polarized**

<b>Wiring</b>	<b>Deutsch</b>
---------------	----------------

Securely insert wires into each terminal as shown.

1. Master monitor station JB-2MD or JB-2MED
2. Sub monitor station JB-2HD or sub station JA-2SD
3. Video entrance station
4. Video or audio entrance station
5. Power supply +, - (DC 18V)
6. Optional door release EL-9S (AC 12 V, 0.35 A) or equivalent, requires a separate AC transformer. Run separate cables for the audio/video and door release.
7. Optional call extension speaker IER-2
8. Impedance matching switch Terminate farthest sub station by putting SW in ON position. Otherwise both video and audio may become distorted.
9. Optional selective door release adaptor RY-3DL Use RY-3DL when connecting a door release for 2 locations.
10. Sensor (locally available)  
Contact your local distributor for details. Use outer equipment (sensor, etc) with dry-closure contacts (CN #2 ORANGE: SG, YELLOW: 5V 11k $\Omega$ )

**NP: Non-polarized**

<b>Wiring</b>	<b>Español</b>
---------------	----------------

Securely insert wires into each terminal as shown.

1. Master monitor station JB-2MD or JB-2MED
2. Sub monitor station JB-2HD or sub station JA-2SD
3. Video entrance station
4. Video or audio entrance station
5. Power supply +, - (DC 18V)
6. Optional door release EL-9S (AC 12 V, 0.35 A) or equivalent, requires a separate AC transformer. Run separate cables for the audio/video and door release.
7. Optional call extension speaker IER-2
8. Impedance matching switch Terminate farthest sub station by putting SW in ON position. Otherwise both video and audio may become distorted.
9. Optional selective door release adaptor RY-3DL Use RY-3DL when connecting a door release for 2 locations.
10. Sensor (locally available)  
Contact your local distributor for details. Use outer equipment (sensor, etc) with dry-closure contacts (CN #2 ORANGE: SG, YELLOW: 5V 11k $\Omega$ )

**NP: Non-polarized**

<b>Wiring</b>	<b>Nederlands</b>
---------------	-------------------

Securely insert wires into each terminal as shown.

1. Master monitor station JB-2MD or JB-2MED
2. Sub monitor station JB-2HD or sub station JA-2SD
3. Video entrance station
4. Video or audio entrance station
5. Power supply +, - (DC 18V)
6. Optional door release EL-9S (AC 12 V, 0.35 A) or equivalent, requires a separate AC transformer. Run separate cables for the audio/video and door release.
7. Optional call extension speaker IER-2
8. Impedance matching switch Terminate farthest sub station by putting SW in ON position. Otherwise both video and audio may become distorted.
9. Optional selective door release adaptor RY-3DL Use RY-3DL when connecting a door release for 2 locations.
10. Sensor (locally available)  
Contact your local distributor for details. Use outer equipment (sensor, etc) with dry-closure contacts (CN #2 ORANGE: SG, YELLOW: 5V 11k $\Omega$ )

**NP: Non-polarized**

# 5

## NAMES NAMES NAMES NAMES

### JB-2MD , JB-2HD

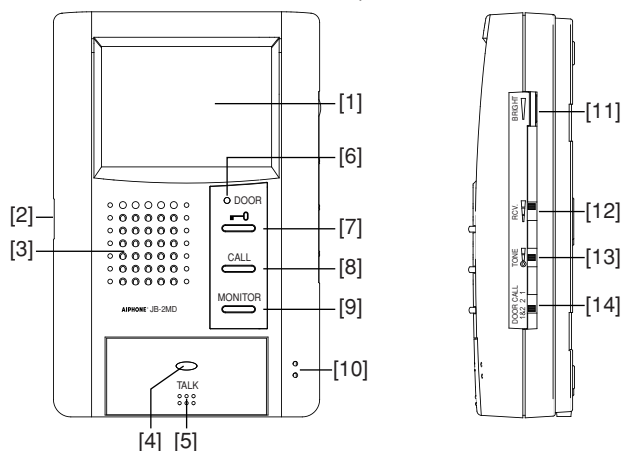

### JB-2MED

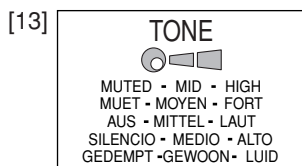
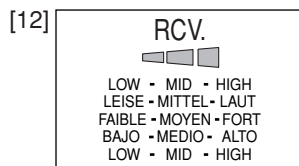
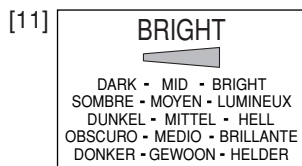
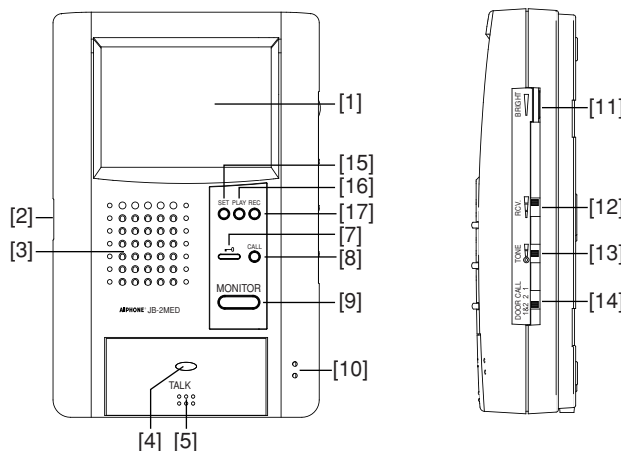

### Names

### English

- [1] LCD (3-1/2" color)
- [2] POWER switch
- [3] Open voice speaker for chime and internal call-in voice
- [4] Transmit LED
- [5] TALK button
- [6] Door call-in LED
- [7] DOOR RELEASE button
- [8] CALL button
- [9] MONITOR button
- [10] Mic.
- [11] Screen brightness control

- [12] Receive volume control
- [13] Chime TONE volume control
- [14] Door call-in selector switch
- [15] SET button
- [16] PLAY button
- [17] REC button

### Names

### Français

- [1] LCD (3-1/2" color)
- [2] POWER switch
- [3] Open voice speaker for chime and internal call-in voice
- [4] Transmit LED
- [5] TALK button
- [6] Door call-in LED
- [7] DOOR RELEASE button
- [8] CALL button
- [9] MONITOR button
- [10] Mic.
- [11] Screen brightness control
- [12] Receive volume control
- [13] Chime TONE volume control
- [14] Door call-in selector switch
- [15] SET button
- [16] PLAY button
- [17] REC button

### Names

### Deutsch

- [1] LCD (3-1/2" color)
- [2] POWER switch
- [3] Open voice speaker for chime and internal call-in voice
- [4] Transmit LED
- [5] TALK button
- [6] Door call-in LED
- [7] DOOR RELEASE button
- [8] CALL button
- [9] MONITOR button
- [10] Mic.
- [11] Screen brightness control
- [12] Receive volume control
- [13] Chime TONE volume control
- [14] Door call-in selector switch
- [15] SET button
- [16] PLAY button
- [17] REC button

### Names

### Español

- [1] LCD (3-1/2" color)
- [2] POWER switch
- [3] Open voice speaker for chime and internal call-in voice
- [4] Transmit LED
- [5] TALK button
- [6] Door call-in LED
- [7] DOOR RELEASE button
- [8] CALL button
- [9] MONITOR button
- [10] Mic.
- [11] Screen brightness control
- [12] Receive volume control
- [13] Chime TONE volume control
- [14] Door call-in selector switch
- [15] SET button
- [16] PLAY button
- [17] REC button

### Names

### Nederlands

- [1] LCD (3-1/2" color)
- [2] POWER switch
- [3] Open voice speaker for chime and internal call-in voice
- [4] Transmit LED
- [5] TALK button
- [6] Door call-in LED
- [7] DOOR RELEASE button
- [8] CALL button

- [9] MONITOR button
- [10] Mic.
- [11] Screen brightness control
- [12] Receive volume control
- [13] Chime TONE volume control
- [14] Door call-in selector switch
- [15] SET button
- [16] PLAY button
- [17] REC button

# 6

## SETTING UP SETTING UP SETTING UP SETTING UP

**JB-2MED**

- 1**
- 2**
- 3**
- 4**
- 5**
- 6**

### Setting up English

- If the SET button is flashing or is on before starting, turn it off with the following method.
  - If it is flashing: Press the PLAY button. When play is complete, press the SET button.
  - If it is on: Press the SET button.
1. Mode selection:  
Press the SET button for 2 seconds or more to select the setting mode.
  2. Setting the position of the date/time display:  
Press the PLAY button to move upward, and the REC button to move downward, and set with the SET button.
  3. Setting the date/time:  
Use the PLAY button (+) and the REC button (-) to adjust the sequence of year \_ month \_ date \_ hour \_ minute, and set with the SET button.
  4. Setting the alarm time:  
Select with the PLAY button to move upward, and the REC button to move downward, and set with the SET button.
  5. Setting record mode:  
Select the number of pictures to be saved. Press PLAY button to move upward, and the REC button to move downward. Set with the SET button.
  6. End:  
Press the TALK button to end the setting process during steps 1 to 5. Otherwise, it will end automatically after 2-1/2 minutes.
- ⚠ 1. If the record mode is changed in step 5, the previously recorded screens are deleted. If you do not wish to delete the screens, do not change the record mode.
- ⚠ 2. If you only want to change a certain item, or if you made a mistake in the settings, you must go through the entire sequence. Start again from "Mode selection".
- ⚠ 3. The setting mode will end automatically after 2-1/2 minutes. If it ends during setting, start again from "Mode selection".

### Setting up Français

- If the SET button is flashing or is on before starting, turn it off with the following method.
  - If it is flashing: Press the PLAY button. When play is complete, press the SET button.
  - If it is on: Press the SET button.
1. Mode selection:  
Press the SET button for 2 seconds or more to select the setting mode.
  2. Setting the position of the date/time display:  
Press the PLAY button to move upward, and the REC button to move downward, and set with the SET button.
  3. Setting the date/time:  
Use the PLAY button (+) and the REC button (-) to adjust the sequence of year \_ month \_ date \_ hour \_ minute, and set with the SET button.
  4. Setting the alarm time:  
Select with the PLAY button to move upward, and the REC button to move downward, and set with the SET button.
  5. Setting record mode:  
Select the number of pictures to be saved. Press PLAY button to move upward, and the REC button to move downward. Set with the SET button.
  6. End:  
Press the TALK button to end the setting process during steps 1 to 5. Otherwise, it will end automatically after 2-1/2 minutes.
- ⚠ 1. If the record mode is changed in step 5, the previously recorded screens are deleted. If you do not wish to delete the screens, do not change the record mode.
- ⚠ 2. If you only want to change a certain item, or if you made a mistake in the settings, you must go through the entire sequence. Start again from "Mode selection".
- ⚠ 3. The setting mode will end automatically after 2-1/2 minutes. If it ends during setting, start again from "Mode selection".

## Setting up

## Deutsch

- If the SET button is flashing or is on before starting, turn it off with the following method.
  - If it is flashing: Press the PLAY button. When play is complete, press the SET button.
  - If it is on: Press the SET button.
1. Mode selection:  
Press the SET button for 2 seconds or more to select the setting mode.
  2. Setting the position of the date/time display:  
Press the PLAY button to move upward, and the REC button to move downward, and set with the SET button.
  3. Setting the date/time:  
Use the PLAY button (+) and the REC button (-) to adjust the sequence of year \_ month \_ date \_ hour \_ minute, and set with the SET button.
  4. Setting the alarm time:  
Select with the PLAY button to move upward, and the REC button to move downward, and set with the SET button.
  5. Setting record mode:  
Select the number of pictures to be saved. Press PLAY button to move upward, and the REC button to move downward. Set with the SET button.
  6. End:  
Press the TALK button to end the setting process during steps 1 to 5. Otherwise, it will end automatically after 2-1/2 minutes.
- ⚠ 1. If the record mode is changed in step 5, the previously recorded screens are deleted. If you do not wish to delete the screens, do not change the record mode.
  - ⚠ 2. If you only want to change a certain item, or if you made a mistake in the settings, you must go through the entire sequence. Start again from "Mode selection".
  - ⚠ 3. The setting mode will end automatically after 2-1/2 minutes. If it ends during setting, start again from "Mode selection".

## Setting up

## Español

- If the SET button is flashing or is on before starting, turn it off with the following method.
  - If it is flashing: Press the PLAY button. When play is complete, press the SET button.
  - If it is on: Press the SET button.
1. Mode selection:  
Press the SET button for 2 seconds or more to select the setting mode.
  2. Setting the position of the date/time display:  
Press the PLAY button to move upward, and the REC button to move downward, and set with the SET button.
  3. Setting the date/time:  
Use the PLAY button (+) and the REC button (-) to adjust the sequence of year \_ month \_ date \_ hour \_ minute, and set with the SET button.
  4. Setting the alarm time:  
Select with the PLAY button to move upward, and the REC button to move downward, and set with the SET button.
  5. Setting record mode:  
Select the number of pictures to be saved. Press PLAY button to move upward, and the REC button to move downward. Set with the SET button.
  6. End:  
Press the TALK button to end the setting process during steps 1 to 5. Otherwise, it will end automatically after 2-1/2 minutes.
- ⚠ 1. If the record mode is changed in step 5, the previously recorded screens are deleted. If you do not wish to delete the screens, do not change the record mode.
  - ⚠ 2. If you only want to change a certain item, or if you made a mistake in the settings, you must go through the entire sequence. Start again from "Mode selection".
  - ⚠ 3. The setting mode will end automatically after 2-1/2 minutes. If it ends during setting, start again from "Mode selection".

## Setting up

## Nederlands

- If the SET button is flashing or is on before starting, turn it off with the following method.

- If it is flashing: Press the PLAY button. When play is complete, press the SET button.
  - If it is on: Press the SET button.
1. Mode selection:  
Press the SET button for 2 seconds or more to select the setting mode.
  2. Setting the position of the date/time display:  
Press the PLAY button to move upward, and the REC button to move downward, and set with the SET button.
  3. Setting the date/time:  
Use the PLAY button (+) and the REC button (-) to adjust the sequence of year \_ month \_ date \_ hour \_ minute, and set with the SET button.
  4. Setting the alarm time:  
Select with the PLAY button to move upward, and the REC button to move downward, and set with the SET button.
  5. Setting record mode:  
Select the number of pictures to be saved. Press PLAY button to move upward, and the REC button to move downward. Set with the SET button.
  6. End:  
Press the TALK button to end the setting process during steps 1 to 5. Otherwise, it will end automatically after 2-1/2 minutes.
- ⚠ 1. If the record mode is changed in step 5, the previously recorded screens are deleted. If you do not wish to delete the screens, do not change the record mode.
  - ⚠ 2. If you only want to change a certain item, or if you made a mistake in the settings, you must go through the entire sequence. Start again from "Mode selection".
  - ⚠ 3. The setting mode will end automatically after 2-1/2 minutes. If it ends during setting, start again from "Mode selection".

# 7 OPERATIONS OPERATIONS OPERATIONS OPERATIONS

## 7-1

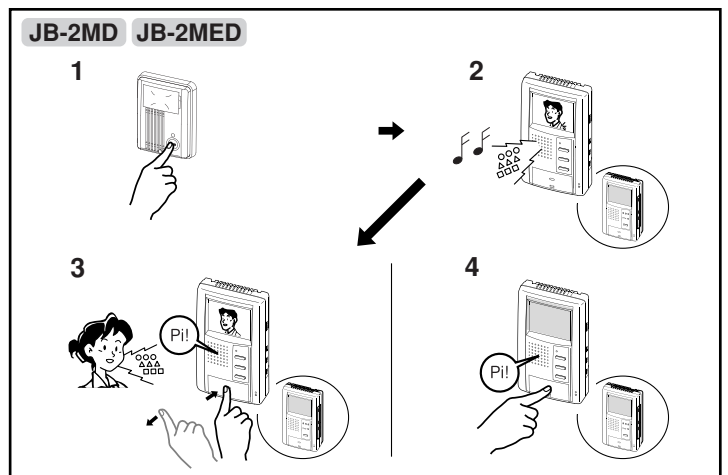

## Answering a door call (Voice actuate mode)

## English

1. The CALL button of the entrance station is pressed.
  2. The chime tone sounds, the caller is seen on the video monitor, and the caller's voice is heard.
  3. Press the TALK button momentarily, then communicate handsfree. The transmit LED lights when you talk, and goes off as you listen to the caller (or hear outside sounds).
  4. Press the TALK button again to end.
- NOTES: 1. In step 2, the video and audio go off after approx. 45 seconds. If the TALK button is pressed within approx. 45 sec., it connects to the caller's entrance station.



2. In step 2, the door call-in LED on the JB-2MED and JB-2HD lights in red if called from entrance station 1, and in green if called from entrance station 2.
3. If there is a lot of noise at the entrance station and conversation is difficult, use the MANUAL Push-to-Talk mode.
4. Communication (video) ends automatically after approx. 1 minute. If the TALK button is pressed within approx. 30 sec., it connects again to the caller's entrance station.
5. If a call is received from an entrance station while already responding to another station, a chime tone sounds only at the master station where communication is taking place. Quickly finish communicating with the first calling entrance station. Press the TALK button again to start communication with the other calling entrance station.
6. If it turns to dark in the evening, LEDs in the door station light on automatically.

<b>Answering a door call (Voice actuate mode)</b>	<b>Français</b>
---	-----------------

1. The CALL button of the entrance station is pressed.
  2. The chime tone sounds, the caller is seen on the video monitor, and the caller's voice is heard.
  3. Press the TALK button momentarily, then communicate handsfree. The transmit LED lights when you talk, and goes off as you listen to the caller (or hear outside sounds).
  4. Press the TALK button again to end.
- NOTES:
1. In step 2, the video and audio go off after approx. 45 seconds. If the TALK button is pressed within approx. 45 sec., it connects to the caller's entrance station.
  2. In step 2, the door call-in LED on the JB-2MED and JB-2HD lights in red if called from entrance station 1, and in green if called from entrance station 2.
  3. If there is a lot of noise at the entrance station and conversation is difficult, use the MANUAL Push-to-Talk mode.
  4. Communication (video) ends automatically after approx. 1 minute. If the TALK button is pressed within approx. 30 sec., it connects again to the caller's entrance station.
  5. If a call is received from an entrance station while already responding to another station, a chime tone sounds only at the master station where communication is taking place. Quickly finish communicating with the first calling entrance station. Press the TALK button again to start communication with the other calling entrance station.
  6. If it turns to dark in the evening, LEDs in the door station light on automatically.

<b>Answering a door call (Voice actuate mode)</b>	<b>Deutsch</b>
---	----------------

1. The CALL button of the entrance station is pressed.
  2. The chime tone sounds, the caller is seen on the video monitor, and the caller's voice is heard.
  3. Press the TALK button momentarily, then communicate handsfree. The transmit LED lights when you talk, and goes off as you listen to the caller (or hear outside sounds).
  4. Press the TALK button again to end.
- NOTES:
1. In step 2, the video and audio go off after approx. 45 seconds. If the TALK button is pressed within approx. 45 sec., it connects to the caller's entrance station.
  2. In step 2, the door call-in LED on the JB-2MED and JB-2HD lights in red if called from entrance station 1, and in green if called from entrance station 2.
  3. If there is a lot of noise at the entrance station and conversation is difficult, use the MANUAL Push-to-Talk mode.
  4. Communication (video) ends automatically after approx. 1 minute. If the TALK button is pressed within approx. 30 sec., it connects again to the caller's entrance station.

5. If a call is received from an entrance station while already responding to another station, a chime tone sounds only at the master station where communication is taking place. Quickly finish communicating with the first calling entrance station. Press the TALK button again to start communication with the other calling entrance station.
6. If it turns to dark in the evening, LEDs in the door station light on automatically.

<b>Answering a door call (Voice actuate mode)</b>	<b>Español</b>
---	----------------

1. The CALL button of the entrance station is pressed.
  2. The chime tone sounds, the caller is seen on the video monitor, and the caller's voice is heard.
  3. Press the TALK button momentarily, then communicate handsfree. The transmit LED lights when you talk, and goes off as you listen to the caller (or hear outside sounds).
  4. Press the TALK button again to end.
- NOTES:
1. In step 2, the video and audio go off after approx. 45 seconds. If the TALK button is pressed within approx. 45 sec., it connects to the caller's entrance station.
  2. In step 2, the door call-in LED on the JB-2MED and JB-2HD lights in red if called from entrance station 1, and in green if called from entrance station 2.
  3. If there is a lot of noise at the entrance station and conversation is difficult, use the MANUAL Push-to-Talk mode.
  4. Communication (video) ends automatically after approx. 1 minute. If the TALK button is pressed within approx. 30 sec., it connects again to the caller's entrance station.
  5. If a call is received from an entrance station while already responding to another station, a chime tone sounds only at the master station where communication is taking place. Quickly finish communicating with the first calling entrance station. Press the TALK button again to start communication with the other calling entrance station.
  6. If it turns to dark in the evening, LEDs in the door station light on automatically.

<b>Answering a door call (Voice actuate mode)</b>	<b>Nederlands</b>
---	-------------------

1. The CALL button of the entrance station is pressed.
  2. The chime tone sounds, the caller is seen on the video monitor, and the caller's voice is heard.
  3. Press the TALK button momentarily, then communicate handsfree. The transmit LED lights when you talk, and goes off as you listen to the caller (or hear outside sounds).
  4. Press the TALK button again to end.
- NOTES:
1. In step 2, the video and audio go off after approx. 45 seconds. If the TALK button is pressed within approx. 45 sec., it connects to the caller's entrance station.
  2. In step 2, the door call-in LED on the JB-2MED and JB-2HD lights in red if called from entrance station 1, and in green if called from entrance station 2.
  3. If there is a lot of noise at the entrance station and conversation is difficult, use the MANUAL Push-to-Talk mode.
  4. Communication (video) ends automatically after approx. 1 minute. If the TALK button is pressed within approx. 30 sec., it connects again to the caller's entrance station.
  5. If a call is received from an entrance station while already responding to another station, a chime tone sounds only at the master station where communication is taking place. Quickly finish communicating with the first calling entrance station. Press the TALK button again to start communication with the other calling entrance station.
  6. If it turns to dark in the evening, LEDs in the door station light on automatically.



## 7-2

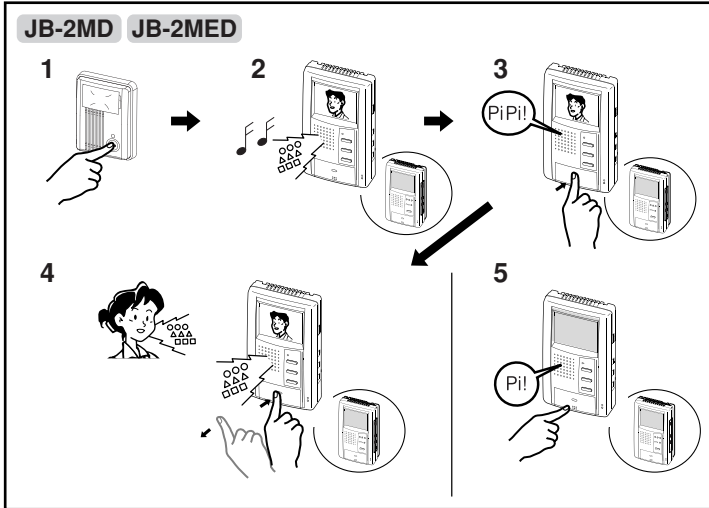

### Answering a door call (MANUAL mode)

English

1. The CALL button of the entrance station is pressed.
2. The chime tone sounds, the caller is seen on the video monitor, and the caller's voice is heard.
3. Press and hold the TALK button for 2 seconds or more.
4. Keep pressing the TALK button to talk, and release to listen to the caller.
5. Press the TALK button momentarily (less than 2 sec.) to end.

- NOTES: 1. In step 2, the video and audio go off after approx. 45 seconds. If the TALK button is pressed within approx. 45 sec., it connects to the caller's entrance station.
2. In step 2, the door call-in LED of the JB-2MED and JB-2HD lights in red if called from entrance station 1, and in green if called from entrance station 2.
  3. If you press the TALK button in step 4 for a short time (less than 2 sec.), communication will end.
  4. Communication (video) ends automatically after approx. 1 minute. If the TALK button is pressed within approx. 30 sec., it connects again to the caller's entrance station.

### Answering a door call (MANUAL mode)

Français

1. The CALL button of the entrance station is pressed.
2. The chime tone sounds, the caller is seen on the video monitor, and the caller's voice is heard.
3. Press and hold the TALK button for 2 seconds or more.
4. Keep pressing the TALK button to talk, and release to listen to the caller.
5. Press the TALK button momentarily (less than 2 sec.) to end.

- NOTES: 1. In step 2, the video and audio go off after approx. 45 seconds. If the TALK button is pressed within approx. 45 sec., it connects to the caller's entrance station.
2. In step 2, the door call-in LED of the JB-2MED and JB-2HD lights in red if called from entrance station 1, and in green if called from entrance station 2.
  3. If you press the TALK button in step 4 for a short time (less than 2 sec.), communication will end.
  4. Communication (video) ends automatically after approx. 1 minute. If the TALK button is pressed within approx. 30 sec., it connects again to the caller's entrance station.

### Answering a door call (MANUAL mode)

Deutsch

1. The CALL button of the entrance station is pressed.
2. The chime tone sounds, the caller is seen on the video monitor, and the caller's voice is heard.
3. Press and hold the TALK button for 2 seconds or more.
4. Keep pressing the TALK button to talk, and release to listen to the caller.
5. Press the TALK button momentarily (less than 2 sec.) to end.

- NOTES: 1. In step 2, the video and audio go off after approx. 45 seconds. If the TALK button is pressed within approx. 45 sec., it connects to the caller's entrance station.

2. In step 2, the door call-in LED of the JB-2MED and JB-2HD lights in red if called from entrance station 1, and in green if called from entrance station 2.
3. If you press the TALK button in step 4 for a short time (less than 2 sec.), communication will end.
4. Communication (video) ends automatically after approx. 1 minute. If the TALK button is pressed within approx. 30 sec., it connects again to the caller's entrance station.

### Answering a door call (MANUAL mode)

Español

1. The CALL button of the entrance station is pressed.
2. The chime tone sounds, the caller is seen on the video monitor, and the caller's voice is heard.
3. Press and hold the TALK button for 2 seconds or more.
4. Keep pressing the TALK button to talk, and release to listen to the caller.
5. Press the TALK button momentarily (less than 2 sec.) to end.

- NOTES: 1. In step 2, the video and audio go off after approx. 45 seconds. If the TALK button is pressed within approx. 45 sec., it connects to the caller's entrance station.
2. In step 2, the door call-in LED of the JB-2MED and JB-2HD lights in red if called from entrance station 1, and in green if called from entrance station 2.
  3. If you press the TALK button in step 4 for a short time (less than 2 sec.), communication will end.
  4. Communication (video) ends automatically after approx. 1 minute. If the TALK button is pressed within approx. 30 sec., it connects again to the caller's entrance station.

### Answering a door call (MANUAL mode)

Nederlands

1. The CALL button of the entrance station is pressed.
2. The chime tone sounds, the caller is seen on the video monitor, and the caller's voice is heard.
3. Press and hold the TALK button for 2 seconds or more.
4. Keep pressing the TALK button to talk, and release to listen to the caller.
5. Press the TALK button momentarily (less than 2 sec.) to end.

- NOTES: 1. In step 2, the video and audio go off after approx. 45 seconds. If the TALK button is pressed within approx. 45 sec., it connects to the caller's entrance station.
2. In step 2, the door call-in LED of the JB-2MED and JB-2HD lights in red if called from entrance station 1, and in green if called from entrance station 2.
  3. If you press the TALK button in step 4 for a short time (less than 2 sec.), communication will end.
  4. Communication (video) ends automatically after approx. 1 minute. If the TALK button is pressed within approx. 30 sec., it connects again to the caller's entrance station.

## 7-3

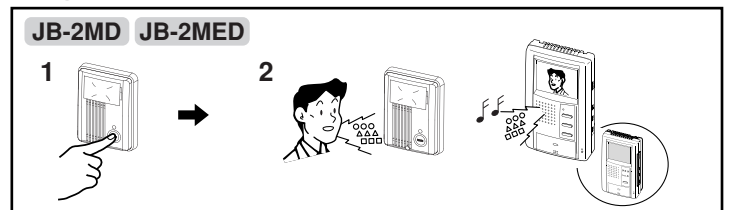

### Instant voice call function

English

1. The CALL button of the entrance station is pressed.
2. Even without answering, the door area can be seen and heard with video and audio (for approx. 45 sec.). Inside sound is not heard outside.

NOTES: JA-D does not have this function. Audio is only established when the call is answered.

### Instant voice call function

Français

1. The CALL button of the entrance station is pressed.
2. Even without answering, the door area can be seen and heard with video and audio (for approx. 45 sec.). Inside sound is not heard outside.

NOTES: JA-D does not have this function. Audio is only established when the call is answered.

**Instant voice call function** Deutsch

1. The CALL button of the entrance station is pressed.
2. Even without answering, the door area can be seen and heard with video and audio (for approx. 45 sec.). Inside sound is not heard outside.

NOTES: JA-D does not have this function. Audio is only established when the call is answered.

**Instant voice call function** Español

1. The CALL button of the entrance station is pressed.
2. Even without answering, the door area can be seen and heard with video and audio (for approx. 45 sec.). Inside sound is not heard outside.

NOTES: JA-D does not have this function. Audio is only established when the call is answered.

**Instant voice call function** Nederlands

1. The CALL button of the entrance station is pressed.
2. Even without answering, the door area can be seen and heard with video and audio (for approx. 45 sec.). Inside sound is not heard outside.

NOTES: JA-D does not have this function. Audio is only established when the call is answered.

## 7-4

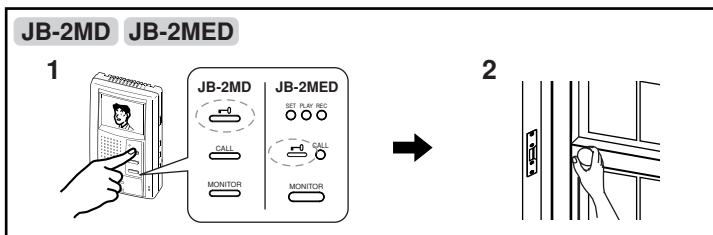

**Activating door release** English

1. Press the DOOR RELEASE button in communication or monitoring.
2. The door is unlocked.

**Activating door release** Français

1. Press the DOOR RELEASE button in communication or monitoring.
2. The door is unlocked.

**Activating door release** Deutsch

1. Press the DOOR RELEASE button in communication or monitoring.
2. The door is unlocked.

**Activating door release** Español

1. Press the DOOR RELEASE button in communication or monitoring.
2. The door is unlocked.

**Activating door release** Nederlands

1. Press the DOOR RELEASE button in communication or monitoring.
2. The door is unlocked.

## 7-5

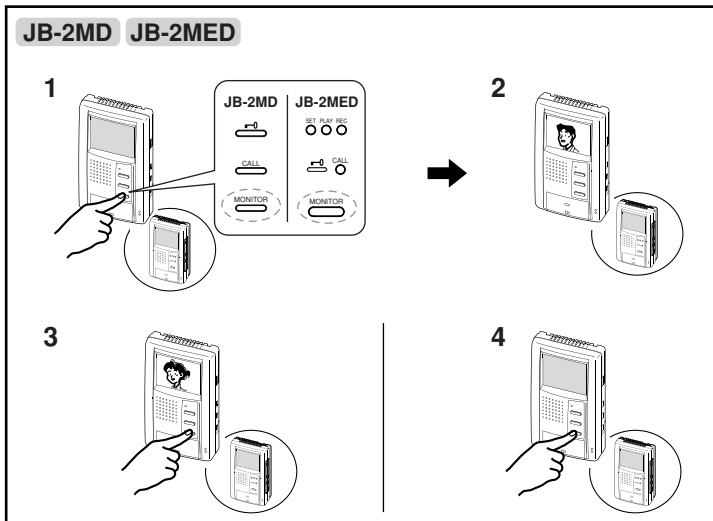

**Entrance monitoring** English

1. Press the MONITOR button.
2. The video monitor displays the image of entrance station 1 and the audio is heard. If you do not press the TALK button, the caller will not hear your voice.
3. Press the entrance MONITOR button again to switch to entrance station 2. If a JA-D (audio only) unit is connected to entrance 2, it is skipped (cannot be monitored).
4. Press the MONITOR button again to end.

NOTES: 1. To talk to the entrance station during monitoring, press and release the TALK button. Press the TALK button again to end the communication.

2. The entrance monitoring ends automatically after approx. 1 min. To monitor the entrance again, repeat from step 1.

3. If a call is received from another entrance station during monitoring, it switches to the calling station.

**Entrance monitoring** Français

1. Press the MONITOR button.
2. The video monitor displays the image of entrance station 1 and the audio is heard. If you do not press the TALK button, the caller will not hear your voice.
3. Press the entrance MONITOR button again to switch to entrance station 2. If a JA-D (audio only) unit is connected to entrance 2, it is skipped (cannot be monitored).
4. Press the MONITOR button again to end.

NOTES: 1. To talk to the entrance station during monitoring, press and release the TALK button. Press the TALK button again to end the communication.

2. The entrance monitoring ends automatically after approx. 1 min. To monitor the entrance again, repeat from step 1.

3. If a call is received from another entrance station during monitoring, it switches to the calling station.

**Entrance monitoring** Deutsch

1. Press the MONITOR button.
2. The video monitor displays the image of entrance station 1 and the audio is heard. If you do not press the TALK button, the caller will not hear your voice.
3. Press the entrance MONITOR button again to switch to entrance station 2. If a JA-D (audio only) unit is connected to entrance 2, it is skipped (cannot be monitored).
4. Press the MONITOR button again to end.

NOTES: 1. To talk to the entrance station during monitoring, press and release the TALK button. Press the TALK button again to end the communication.

2. The entrance monitoring ends automatically after approx. 1 min. To monitor the entrance again, repeat from step 1.

3. If a call is received from another entrance station during monitoring, it switches to the calling station.

**Entrance monitoring** Español

1. Press the MONITOR button.
2. The video monitor displays the image of entrance station 1 and the audio is heard. If you do not press the TALK button, the caller will not hear your voice.
3. Press the entrance MONITOR button again to switch to entrance station 2. If a JA-D (audio only) unit is connected to entrance 2, it is skipped (cannot be monitored).
4. Press the MONITOR button again to end.

NOTES: 1. To talk to the entrance station during monitoring, press and release the TALK button. Press the TALK button again to end the communication.

2. The entrance monitoring ends automatically after approx. 1 min. To monitor the entrance again, repeat from step 1.

3. If a call is received from another entrance station during monitoring, it switches to the calling station.

**Entrance monitoring****Nederlands**

1. Press the MONITOR button.
2. The video monitor displays the image of entrance station 1 and the audio is heard. If you do not press the TALK button, the caller will not hear your voice.
3. Press the entrance MONITOR button again to switch to entrance station 2. If a JA-D (audio only) unit is connected to entrance 2, it is skipped (cannot be monitored).
4. Press the MONITOR button again to end.

- NOTES: 1. To talk to the entrance station during monitoring, press and release the TALK button. Press the TALK button again to end the communication.
2. The entrance monitoring ends automatically after approx. 1 min. To monitor the entrance again, repeat from step 1.
  3. If a call is received from another entrance station during monitoring, it switches to the calling station.

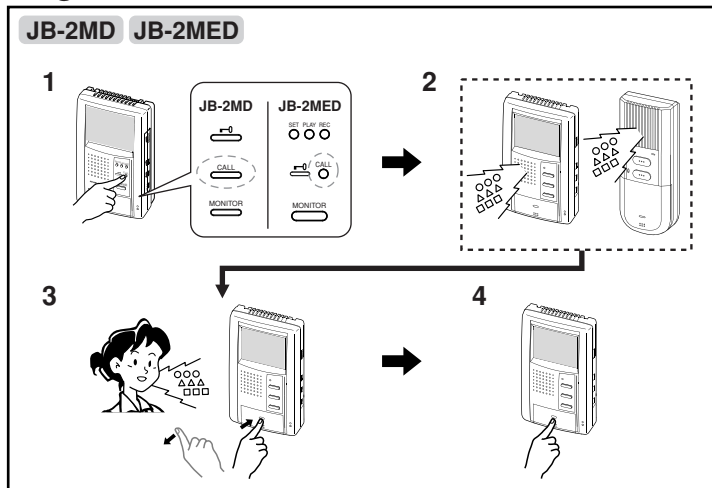
**7-6****Room-to-room communication****English**

1. Press the CALL button once.
2. The "All Call" function is activated to link all of the inside stations.
3. If another person presses the TALK button, handsfree communication is possible.
4. Press and release the TALK button to end.

- ⚠ 1. Do not press the TALK button during communication in step 3. It will end the communication.

- NOTES: 1. Room-to-room communication ends automatically after approx. 1 minute. To have another room-to-room conversation, repeat from step 1.
2. If a call is received from an entrance station during room-to-room communication, a chime tone sounds only at the master station where communication is taking place. Quickly end room-to-room communication, then the system switches to the calling entrance station.

**Room-to-room communication****Français**

1. Press the CALL button once.
2. The "All Call" function is activated to link all of the inside stations.
3. If another person presses the TALK button, handsfree communication is possible.
4. Press and release the TALK button to end.

- ⚠ 1. Do not press the TALK button during communication in step 3. It will end the communication.

- NOTES: 1. Room-to-room communication ends automatically after approx. 1 minute. To have another room-to-room conversation, repeat from step 1.
2. If a call is received from an entrance station during room-to-room communication, a chime tone sounds only at the master station where communication is taking place. Quickly end room-to-room communication, then the system switches to the calling entrance station.

**Room-to-room communication****Deutsch**

1. Press the CALL button once.

2. The "All Call" function is activated to link all of the inside stations.
3. If another person presses the TALK button, handsfree communication is possible.
4. Press and release the TALK button to end.

- ⚠ 1. Do not press the TALK button during communication in step 3. It will end the communication.

- NOTES: 1. Room-to-room communication ends automatically after approx. 1 minute. To have another room-to-room conversation, repeat from step 1.
2. If a call is received from an entrance station during room-to-room communication, a chime tone sounds only at the master station where communication is taking place. Quickly end room-to-room communication, then the system switches to the calling entrance station.

**Room-to-room communication****Español**

1. Press the CALL button once.
2. The "All Call" function is activated to link all of the inside stations.
3. If another person presses the TALK button, handsfree communication is possible.
4. Press and release the TALK button to end.

- ⚠ 1. Do not press the TALK button during communication in step 3. It will end the communication.

- NOTES: 1. Room-to-room communication ends automatically after approx. 1 minute. To have another room-to-room conversation, repeat from step 1.
2. If a call is received from an entrance station during room-to-room communication, a chime tone sounds only at the master station where communication is taking place. Quickly end room-to-room communication, then the system switches to the calling entrance station.

**Room-to-room communication****Nederlands**

1. Press the CALL button once.
2. The "All Call" function is activated to link all of the inside stations.
3. If another person presses the TALK button, handsfree communication is possible.
4. Press and release the TALK button to end.

- ⚠ 1. Do not press the TALK button during communication in step 3. It will end the communication.

- NOTES: 1. Room-to-room communication ends automatically after approx. 1 minute. To have another room-to-room conversation, repeat from step 1.
2. If a call is received from an entrance station during room-to-room communication, a chime tone sounds only at the master station where communication is taking place. Quickly end room-to-room communication, then the system switches to the calling entrance station.

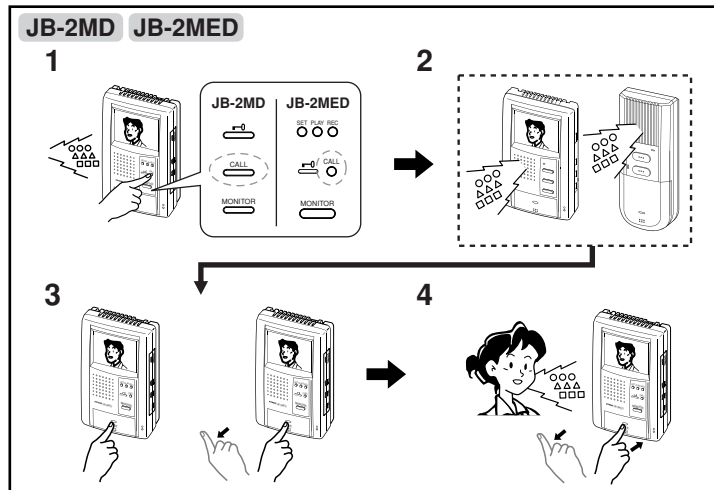
**7-7****Transfer entrance call****English**

1. Press the CALL button during communication with an entrance station.
2. An image of the entrance is displayed on all of the monitor stations.



3. If the transferred station presses the TALK button, room-to-room communication starts.
4. If the transferred station presses the TALK button again, it switches to entrance station calling mode. By pressing the TALK button once more, communication is established with the entrance station. To end, press and release the TALK button.

NOTES: 1. The call-in from the entrance station will be held for 45 seconds. End the room-to-room communication within this timeframe.  
2. Communication ends automatically after approx. 1 min.

**Transfer entrance call** **Français**

1. Press the CALL button during communication with an entrance station.
2. An image of the entrance is displayed on all of the monitor stations.
3. If the transferred station presses the TALK button, room-to-room communication starts.
4. If the transferred station presses the TALK button again, it switches to entrance station calling mode. By pressing the TALK button once more, communication is established with the entrance station. To end, press and release the TALK button.

NOTES: 1. The call-in from the entrance station will be held for 45 seconds. End the room-to-room communication within this timeframe.  
2. Communication ends automatically after approx. 1 min.

**Transfer entrance call** **Deutsch**

1. Press the CALL button during communication with an entrance station.
2. An image of the entrance is displayed on all of the monitor stations.
3. If the transferred station presses the TALK button, room-to-room communication starts.
4. If the transferred station presses the TALK button again, it switches to entrance station calling mode. By pressing the TALK button once more, communication is established with the entrance station. To end, press and release the TALK button.

NOTES: 1. The call-in from the entrance station will be held for 45 seconds. End the room-to-room communication within this timeframe.  
2. Communication ends automatically after approx. 1 min.

**Transfer entrance call** **Español**

1. Press the CALL button during communication with an entrance station.
2. An image of the entrance is displayed on all of the monitor stations.
3. If the transferred station presses the TALK button, room-to-room communication starts.
4. If the transferred station presses the TALK button again, it switches to entrance station calling mode. By pressing the TALK button once more, communication is established with the entrance station. To end, press and release the TALK button.

NOTES: 1. The call-in from the entrance station will be held for 45 seconds. End the room-to-room communication within this timeframe.  
2. Communication ends automatically after approx. 1 min.

**Transfer entrance call** **Nederlands**

1. Press the CALL button during communication with an entrance station.
2. An image of the entrance is displayed on all of the monitor stations.
3. If the transferred station presses the TALK button, room-to-room communication starts.
4. If the transferred station presses the TALK button again, it switches to entrance station calling mode. By pressing the TALK button once more, communication is established with the entrance station. To end, press and release the TALK button.

NOTES: 1. The call-in from the entrance station will be held for 45 seconds. End the room-to-room communication within this timeframe.  
2. Communication ends automatically after approx. 1 min.

## 7-8

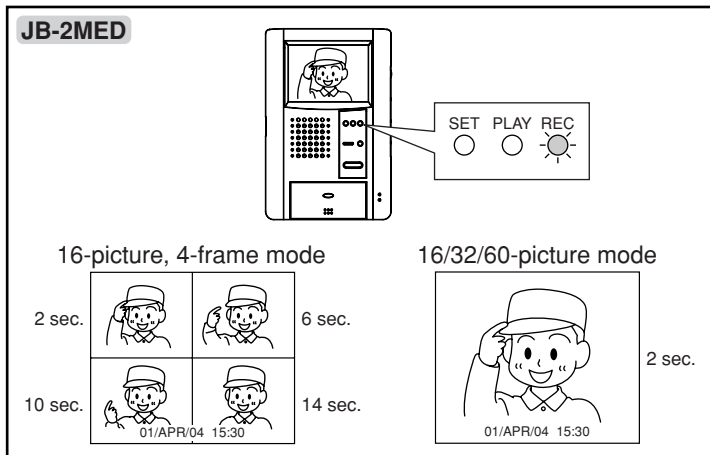

**Automatic recording** **English**

If a call is received from the entrance, the unit starts recording automatically. The REC button lights during recording.

- 16-picture/4-frame mode: Records at approx. 2 sec., 6 sec., 10 sec. and 14 sec. from time of call-in.
- 16/32/60-picture mode: Records after approx. 2 sec.

NOTES: 1. The automatic recording function cannot be cancelled.  
2. The screen shown when monitoring the entrance is not recorded automatically. If you wish to record this screen, press REC button.  
3. When automatic recording has finished, for approx. 15 sec. after the monitor screen goes off, automatic recording will not be activated for the same entrance station even if a call is placed (to prevent prank calls).

**Automatic recording** **Français**

If a call is received from the entrance, the unit starts recording automatically. The REC button lights during recording.

- 16-picture/4-frame mode: Records at approx. 2 sec., 6 sec., 10 sec. and 14 sec. from time of call-in.
- 16/32/60-picture mode: Records after approx. 2 sec.

NOTES: 1. The automatic recording function cannot be cancelled.  
2. The screen shown when monitoring the entrance is not recorded automatically. If you wish to record this screen, press REC button.  
3. When automatic recording has finished, for approx. 15 sec. after the monitor screen goes off, automatic recording will not be activated for the same entrance station even if a call is placed (to prevent prank calls).

**Automatic recording** **Deutsch**

If a call is received from the entrance, the unit starts recording automatically. The REC button lights during recording.

- 16-picture/4-frame mode: Records at approx. 2 sec., 6 sec., 10 sec. and 14 sec. from time of call-in.
- 16/32/60-picture mode: Records after approx. 2 sec.

NOTES: 1. The automatic recording function cannot be cancelled.  
2. The screen shown when monitoring the entrance is not recorded automatically. If you wish to record this screen, press REC button.  
3. When automatic recording has finished, for approx. 15 sec. after the monitor screen goes off, automatic recording will not be activated for the same entrance station even if a call is placed (to prevent prank calls).

**Automatic recording** Español

If a call is received from the entrance, the unit starts recording automatically. The REC button lights during recording.

- 16-picture/4-frame mode: Records at approx. 2 sec., 6 sec., 10 sec. and 14 sec. from time of call-in.
- 16/32/60-picture mode: Records after approx. 2 sec.

- NOTES: 1. The automatic recording function cannot be cancelled.  
 2. The screen shown when monitoring the entrance is not recorded automatically. If you wish to record this screen, press REC button.  
 3. When automatic recording has finished, for approx. 15 sec. after the monitor screen goes off, automatic recording will not be activated for the same entrance station even if a call is placed (to prevent prank calls).

**Automatic recording** Nederlands

If a call is received from the entrance, the unit starts recording automatically. The REC button lights during recording.

- 16-picture/4-frame mode: Records at approx. 2 sec., 6 sec., 10 sec. and 14 sec. from time of call-in.
- 16/32/60-picture mode: Records after approx. 2 sec.

- NOTES: 1. The automatic recording function cannot be cancelled.  
 2. The screen shown when monitoring the entrance is not recorded automatically. If you wish to record this screen, press REC button.  
 3. When automatic recording has finished, for approx. 15 sec. after the monitor screen goes off, automatic recording will not be activated for the same entrance station even if a call is placed (to prevent prank calls).

**7-9**

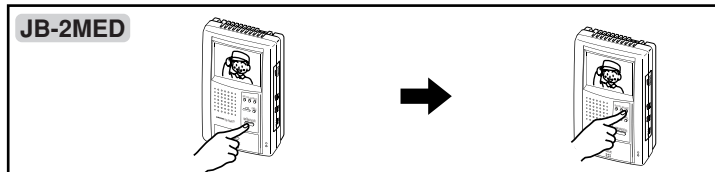

**Manual recording** English

1. Display a video image with the entrance MONITOR button.
2. Press the REC button. The REC button lights and recording starts.

- NOTES: 1. Even if 16-picture/4-frame mode is selected, only 1 frame is recorded in manual mode.  
 2. If manual recording is activated when a call is received from an entrance station, it overwrites the automatically recorded image.

**Manual recording** Français

1. Display a video image with the entrance MONITOR button.
2. Press the REC button. The REC button lights and recording starts.

- NOTES: 1. Even if 16-picture/4-frame mode is selected, only 1 frame is recorded in manual mode.  
 2. If manual recording is activated when a call is received from an entrance station, it overwrites the automatically recorded image.

**Manual recording** Deutsch

1. Display a video image with the entrance MONITOR button.
2. Press the REC button. The REC button lights and recording starts.

- NOTES: 1. Even if 16-picture/4-frame mode is selected, only 1 frame is recorded in manual mode.  
 2. If manual recording is activated when a call is received from an entrance station, it overwrites the automatically recorded image.

**Manual recording** Español

1. Display a video image with the entrance MONITOR button.
2. Press the REC button. The REC button lights and recording starts.

- NOTES: 1. Even if 16-picture/4-frame mode is selected, only 1 frame is recorded in manual mode.  
 2. If manual recording is activated when a call is received from an entrance station, it overwrites the automatically recorded image.

**Manual recording** Nederlands

1. Display a video image with the entrance MONITOR button.
2. Press the REC button. The REC button lights and recording starts.

- NOTES: 1. Even if 16-picture/4-frame mode is selected, only 1 frame is recorded in manual mode.  
 2. If manual recording is activated when a call is received from an entrance station, it overwrites the automatically recorded image.

**7-10**

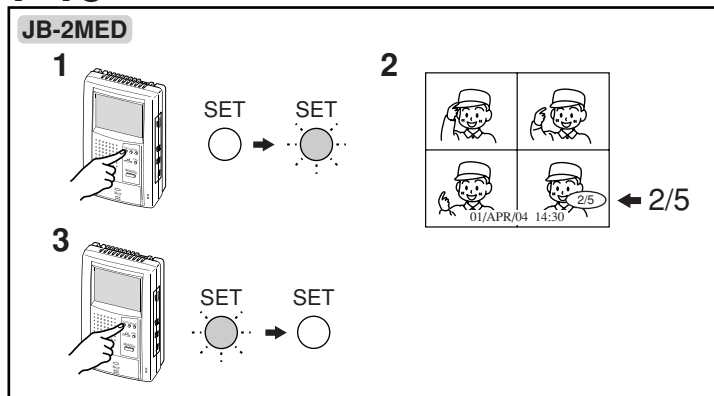

**Absence set (Auto absence recording)** English

1. If the SET button is pressed once (less than 2 sec.), it will light and the unit will be set.
2. If the absence set (auto absence recording) is operating, the SET button flashes to show that there has been a caller (if the image is played, it goes back to being lit). When the image is played, the number of callers who came while you were out is displayed. Example: "2/5" means Second image from a total of 5.
3. Press the SET button again to cancel. The SET button light will go off.

- ⚠ 1. In step 1, if pressed and held for more than 2 sec., it will enter setting mode.

**Absence set (Auto absence recording)** Français

1. If the SET button is pressed once (less than 2 sec.), it will light and the unit will be set.
2. If the absence set (auto absence recording) is operating, the SET button flashes to show that there has been a caller (if the image is played, it goes back to being lit). When the image is played, the number of callers who came while you were out is displayed. Example: "2/5" means Second image from a total of 5.
3. Press the SET button again to cancel. The SET button light will go off.

- ⚠ 1. In step 1, if pressed and held for more than 2 sec., it will enter setting mode.

**Absence set (Auto absence recording)** Deutsch

1. If the SET button is pressed once (less than 2 sec.), it will light and the unit will be set.
2. If the absence set (auto absence recording) is operating, the SET button flashes to show that there has been a caller (if the image is played, it goes back to being lit). When the image is played, the number of callers who came while you were out is displayed. Example: "2/5" means Second image from a total of 5.
3. Press the SET button again to cancel. The SET button light will go off.

- ⚠ 1. In step 1, if pressed and held for more than 2 sec., it will enter setting mode.

**Absence set (Auto absence recording)** Español

1. If the SET button is pressed once (less than 2 sec.), it will light and the unit will be set.



- If the absence set (auto absence recording) is operating, the SET button flashes to show that there has been a caller (if the image is played, it goes back to being lit). When the image is played, the number of callers who came while you were out is displayed.  
Example: "2/5" means Second image from a total of 5.
- Press the SET button again to cancel. The SET button light will go off.

NOTES: Cancellation in step 3 is not possible while the SET button is flashing. First play the recorded screen.

### Absence set (Auto absence recording) Nederlands

- If the SET button is pressed once (less than 2 sec.), it will light and the unit will be set.
- If the absence set (auto absence recording) is operating, the SET button flashes to show that there has been a caller (if the image is played, it goes back to being lit). When the image is played, the number of callers who came while you were out is displayed.  
Example: "2/5" means Second image from a total of 5.
- Press the SET button again to cancel. The SET button light will go off.

NOTES: Cancellation in step 3 is not possible while the SET button is flashing. First play the recorded screen.

## 7-11

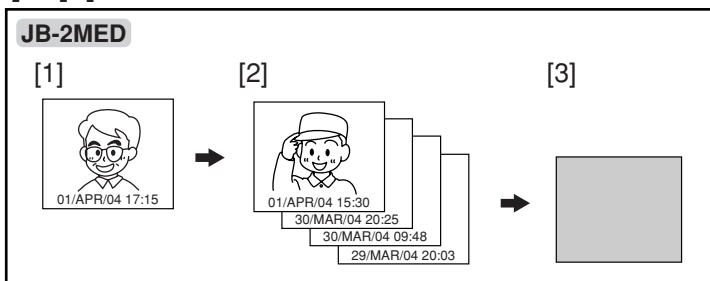

### Automatic updating function for recorded screens English

If the number of recorded pictures exceeds the maximum number set for recording mode, the oldest picture is automatically replaced with the new picture (pictures are erased even if they have not been played).

- Adding new picture
- Number of pictures set for recording mode
- Erasing the earliest taken picture

NOTES: You can save pictures that you want to keep. (P22)

### Automatic updating function for recorded screens Français

If the number of recorded pictures exceeds the maximum number set for recording mode, the oldest picture is automatically replaced with the new picture (pictures are erased even if they have not been played).

- Adding new picture
- Number of pictures set for recording mode
- Erasing the earliest taken picture

NOTES: You can save pictures that you want to keep. (P22)

### Automatic updating function for recorded screens Deutsch

If the number of recorded pictures exceeds the maximum number set for recording mode, the oldest picture is automatically replaced with the new picture (pictures are erased even if they have not been played).

- Adding new picture
- Number of pictures set for recording mode
- Erasing the earliest taken picture

NOTES: You can save pictures that you want to keep. (P22)

### Automatic updating function for recorded screens Español

If the number of recorded pictures exceeds the maximum number set for recording mode, the oldest picture is automatically replaced with the new picture (pictures are erased even if they have not been played).

- Adding new picture
- Number of pictures set for recording mode
- Erasing the earliest taken picture

NOTES: You can save pictures that you want to keep. (P22)

### Automatic updating function for recorded screens Nederlands

If the number of recorded pictures exceeds the maximum number set for recording mode, the oldest picture is automatically replaced with the new picture (pictures are erased even if they have not been played).

- Adding new picture
- Number of pictures set for recording mode
- Erasing the earliest taken picture

NOTES: You can save pictures that you want to keep. (P22)

## 7-12

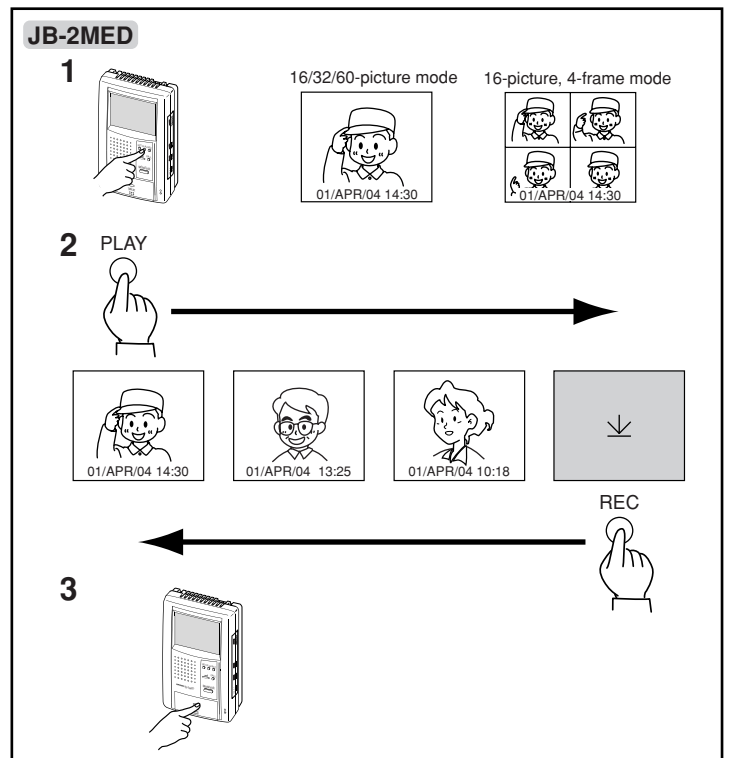

### Play English

- Press the PLAY button to view the newest picture.
- Each time the PLAY button is pressed, it moves to the next picture that was previously recorded. After the final picture, it becomes a blue screen before returning to the first picture. Press the REC button to reverse the selection direction.
- Press the TALK button to end. It ends automatically approx. 1 min. after the final operation.

- In step 1, playback is not possible if there are no recorded pictures.
- In 16-picture/4-frame mode, the REC button in step 2 is used to view each picture in a full-screen view.

### Play Français

- Press the PLAY button to view the newest picture.
- Each time the PLAY button is pressed, it moves to the next picture that was previously recorded. After the final picture, it becomes a blue screen before returning to the first picture. Press the REC button to reverse the selection direction.
- Press the TALK button to end. It ends automatically approx. 1 min. after the final operation.

- In step 1, playback is not possible if there are no recorded pictures.
- In 16-picture/4-frame mode, the REC button in step 2 is used to view each picture in a full-screen view.

### Play Deutsch

- Press the PLAY button to view the newest picture.
- Each time the PLAY button is pressed, it moves to the next picture that was previously recorded. After the final picture, it becomes a blue screen before returning to the first picture. Press the REC button to reverse the selection direction.
- Press the TALK button to end. It ends automatically approx. 1 min. after the final operation.

- In step 1, playback is not possible if there are no recorded pictures.
- In 16-picture/4-frame mode, the REC button in step 2 is used to view each picture in a full-screen view.

**Play** **Español**

1. Press the PLAY button to view the newest picture.
  2. Each time the PLAY button is pressed, it moves to the next picture that was previously recorded. After the final picture, it becomes a blue screen before returning to the first picture. Press the REC button to reverse the selection direction.
  3. Press the TALK button to end. It ends automatically approx. 1 min. after the final operation.
- ⚠ 1. In step 1, playback is not possible if there are no recorded pictures.  
 ⚠ 2. In 16-picture/4-frame mode, the REC button in step 2 is used to view each picture in a full-screen view.

**Play** **Nederlands**

1. Press the PLAY button to view the newest picture.
  2. Each time the PLAY button is pressed, it moves to the next picture that was previously recorded. After the final picture, it becomes a blue screen before returning to the first picture. Press the REC button to reverse the selection direction.
  3. Press the TALK button to end. It ends automatically approx. 1 min. after the final operation.
- ⚠ 1. In step 1, playback is not possible if there are no recorded pictures.  
 ⚠ 2. In 16-picture/4-frame mode, the REC button in step 2 is used to view each picture in a full-screen view.

# 7-13

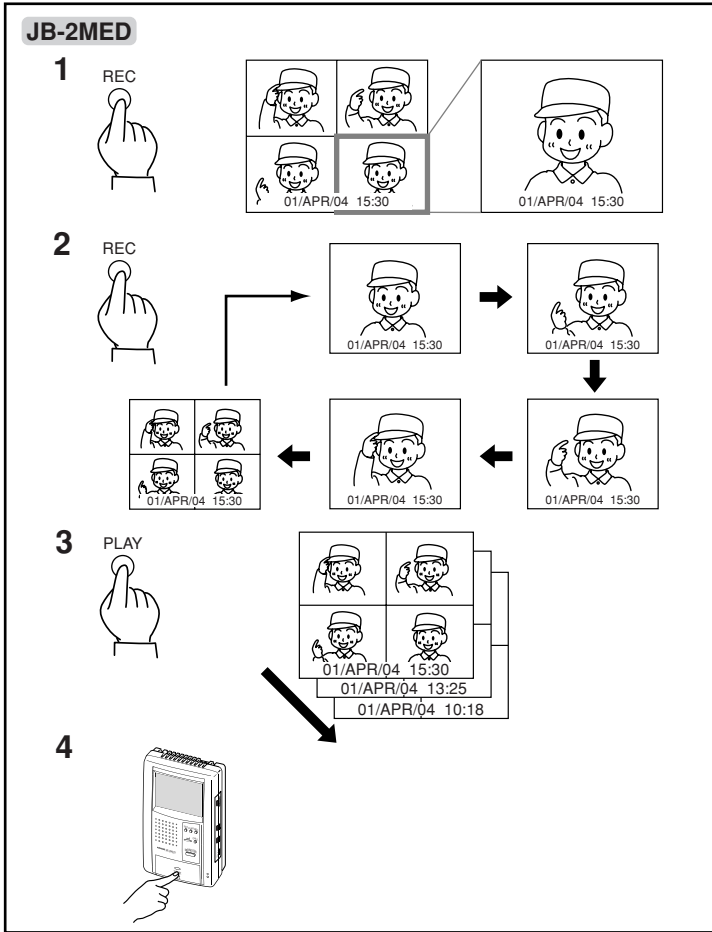

**Sub screen enlargement (16-picture/4-frame mode only)** **English**

1. If the REC button is pressed when playing a 4-frame picture (P20), the last picture (taken after 14 sec.) is enlarged.
  2. Press the REC button again to enlarge the previous sub screen (after 10 sec.). Repeat in sequence for the other sub screens. After the end of sub screen enlargement, it returns to the 4-frame screen.
  3. Press the PLAY button to display the next previously recorded picture (in 4-frame mode).
  4. Press the TALK button to end. It ends automatically approx. 1 minute after the final operation.
- ⚠ In 16-picture/4-frame mode, the selection sequence cannot be reversed. Pictures recorded manually (not divided into 4 frames) cannot be enlarged.

**Sub screen enlargement (16-picture/4-frame mode only)** **Français**

1. If the REC button is pressed when playing a 4-frame picture (P20), the last picture (taken after 14 sec.) is enlarged.
  2. Press the REC button again to enlarge the previous sub screen (after 10 sec.). Repeat in sequence for the other sub screens. After the end of sub screen enlargement, it returns to the 4-frame screen.
  3. Press the PLAY button to display the next previously recorded picture (in 4-frame mode).
  4. Press the TALK button to end. It ends automatically approx. 1 minute after the final operation.
- ⚠ In 16-picture/4-frame mode, the selection sequence cannot be reversed. Pictures recorded manually (not divided into 4 frames) cannot be enlarged.

**Sub screen enlargement (16-picture/4-frame mode only)** **Deutsch**

1. If the REC button is pressed when playing a 4-frame picture (P20), the last picture (taken after 14 sec.) is enlarged.
  2. Press the REC button again to enlarge the previous sub screen (after 10 sec.). Repeat in sequence for the other sub screens. After the end of sub screen enlargement, it returns to the 4-frame screen.
  3. Press the PLAY button to display the next previously recorded picture (in 4-frame mode).
  4. Press the TALK button to end. It ends automatically approx. 1 minute after the final operation.
- ⚠ In 16-picture/4-frame mode, the selection sequence cannot be reversed. Pictures recorded manually (not divided into 4 frames) cannot be enlarged.

**Sub screen enlargement (16-picture/4-frame mode only)** **Español**

1. If the REC button is pressed when playing a 4-frame picture (P20), the last picture (taken after 14 sec.) is enlarged.
  2. Press the REC button again to enlarge the previous sub screen (after 10 sec.). Repeat in sequence for the other sub screens. After the end of sub screen enlargement, it returns to the 4-frame screen.
  3. Press the PLAY button to display the next previously recorded picture (in 4-frame mode).
  4. Press the TALK button to end. It ends automatically approx. 1 minute after the final operation.
- ⚠ In 16-picture/4-frame mode, the selection sequence cannot be reversed. Pictures recorded manually (not divided into 4 frames) cannot be enlarged.

**Sub screen enlargement (16-picture/4-frame mode only)** **Nederlands**

1. If the REC button is pressed when playing a 4-frame picture (P20), the last picture (taken after 14 sec.) is enlarged.
  2. Press the REC button again to enlarge the previous sub screen (after 10 sec.). Repeat in sequence for the other sub screens. After the end of sub screen enlargement, it returns to the 4-frame screen.
  3. Press the PLAY button to display the next previously recorded picture (in 4-frame mode).
  4. Press the TALK button to end. It ends automatically approx. 1 minute after the final operation.
- ⚠ In 16-picture/4-frame mode, the selection sequence cannot be reversed. Pictures recorded manually (not divided into 4 frames) cannot be enlarged.

# 7-14

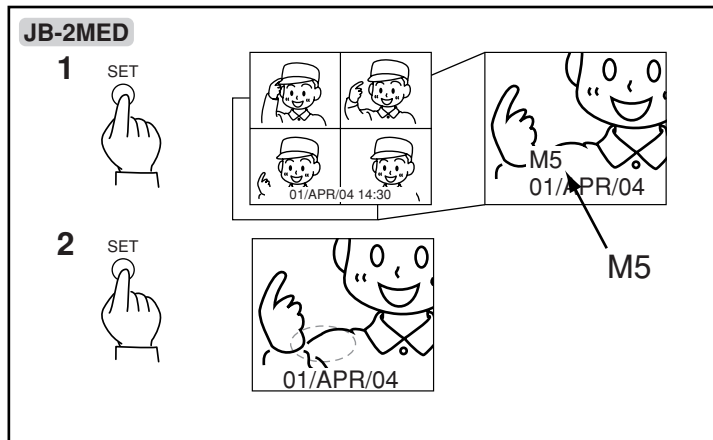



### Save

### English

1. Press the SET button during play (P20) to save the picture. "M" is displayed to show it has been saved, and the number of the saved pictures is also displayed. A maximum of 8 pictures can be saved. Example: "M5" means that 5 pictures have been saved.
  2. Press the SET button when playing a saved picture to cancel the saving function and delete the "M".
- NOTES:
1. If SAVE is operated during the playing of an individual picture in the 4-frame mode, all of the 4 pictures are saved on a single screen.
  2. If you try to save a ninth picture, "FULL" will be displayed in the middle of the screen.
  3. In step 2, the saving function is cancelled, but the picture itself is not erased. However it will be overwritten (erased) if a new picture is recorded.
  4. Saved pictures cannot be overwritten by other operations, except the erase function. (P23)

### Save

### Français

1. Press the SET button during play (P20) to save the picture. "M" is displayed to show it has been saved, and the number of the saved pictures is also displayed. A maximum of 8 pictures can be saved. Example: "M5" means that 5 pictures have been saved.
  2. Press the SET button when playing a saved picture to cancel the saving function and delete the "M".
- NOTES:
1. If SAVE is operated during the playing of an individual picture in the 4-frame mode, all of the 4 pictures are saved on a single screen.
  2. If you try to save a ninth picture, "FULL" will be displayed in the middle of the screen.
  3. In step 2, the saving function is cancelled, but the picture itself is not erased. However it will be overwritten (erased) if a new picture is recorded.
  4. Saved pictures cannot be overwritten by other operations, except the erase function. (P23)

### Save

### Deutsch

1. Press the SET button during play (P20) to save the picture. "M" is displayed to show it has been saved, and the number of the saved pictures is also displayed. A maximum of 8 pictures can be saved. Example: "M5" means that 5 pictures have been saved.
  2. Press the SET button when playing a saved picture to cancel the saving function and delete the "M".
- NOTES:
1. If SAVE is operated during the playing of an individual picture in the 4-frame mode, all of the 4 pictures are saved on a single screen.
  2. If you try to save a ninth picture, "FULL" will be displayed in the middle of the screen.
  3. In step 2, the saving function is cancelled, but the picture itself is not erased. However it will be overwritten (erased) if a new picture is recorded.
  4. Saved pictures cannot be overwritten by other operations, except the erase function. (P23)

### Save

### Español

1. Press the SET button during play (P20) to save the picture. "M" is displayed to show it has been saved, and the number of the saved pictures is also displayed. A maximum of 8 pictures can be saved. Example: "M5" means that 5 pictures have been saved.
  2. Press the SET button when playing a saved picture to cancel the saving function and delete the "M".
- NOTES:
1. If SAVE is operated during the playing of an individual picture in the 4-frame mode, all of the 4 pictures are saved on a single screen.
  2. If you try to save a ninth picture, "FULL" will be displayed in the middle of the screen.

3. In step 2, the saving function is cancelled, but the picture itself is not erased. However it will be overwritten (erased) if a new picture is recorded.
4. Saved pictures cannot be overwritten by other operations, except the erase function. (P23)

### Save

### Nederlands

1. Press the SET button during play (P20) to save the picture. "M" is displayed to show it has been saved, and the number of the saved pictures is also displayed. A maximum of 8 pictures can be saved. Example: "M5" means that 5 pictures have been saved.
  2. Press the SET button when playing a saved picture to cancel the saving function and delete the "M".
- NOTES:
1. If SAVE is operated during the playing of an individual picture in the 4-frame mode, all of the 4 pictures are saved on a single screen.
  2. If you try to save a ninth picture, "FULL" will be displayed in the middle of the screen.
  3. In step 2, the saving function is cancelled, but the picture itself is not erased. However it will be overwritten (erased) if a new picture is recorded.
  4. Saved pictures cannot be overwritten by other operations, except the erase function. (P23)

## 7-15

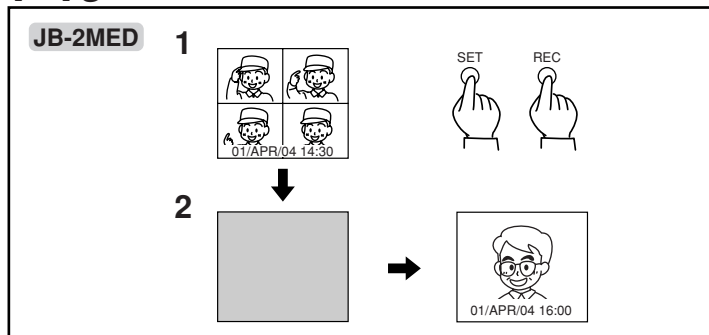

### Erase

### English

1. Use the play operation to display the picture you wish to erase. (P20) Push the SET button and REC button simultaneously for 2 sec. to erase.
2. The picture to be erased is deleted, and the next picture will be displayed. When the next picture is displayed, let go of the button.
  - ⚠ 1. Erase operations will also erase saved pictures.
  - ⚠ 2. Once a picture is erased, it cannot be restored.
  - ⚠ 3. It is not possible to delete only a single sub screen of a 4-frame picture recorded in 16-picture/4-frame mode.
  - ⚠ 4. To erase all of the pictures, change recording mode in the settings. This will erase all of the pictures recorded up to that point. (P12)

### Erase

### Français

1. Use the play operation to display the picture you wish to erase. (P20) Push the SET button and REC button simultaneously for 2 sec. to erase.
2. The picture to be erased is deleted, and the next picture will be displayed. When the next picture is displayed, let go of the button.
  - ⚠ 1. Erase operations will also erase saved pictures.
  - ⚠ 2. Once a picture is erased, it cannot be restored.
  - ⚠ 3. It is not possible to delete only a single sub screen of a 4-frame picture recorded in 16-picture/4-frame mode.
  - ⚠ 4. To erase all of the pictures, change recording mode in the settings. This will erase all of the pictures recorded up to that point. (P12)



**Erase** **Deutsch**

1. Use the play operation to display the picture you wish to erase. (P20)  
Push the SET button and REC button simultaneously for 2 sec. to erase.
  2. The picture to be erased is deleted, and the next picture will be displayed. When the next picture is displayed, let go of the button.
- ⚠ 1. Erase operations will also erase saved pictures.
  - ⚠ 2. Once a picture is erased, it cannot be restored.
  - ⚠ 3. It is not possible to delete only a single sub screen of a 4-frame picture recorded in 16-picture/4-frame mode.
  - ⚠ 4. To erase all of the pictures, change recording mode in the settings. This will erase all of the pictures recorded up to that point. (P12)

**Erase** **Español**

1. Use the play operation to display the picture you wish to erase. (P20)  
Push the SET button and REC button simultaneously for 2 sec. to erase.
  2. The picture to be erased is deleted, and the next picture will be displayed. When the next picture is displayed, let go of the button.
- ⚠ 1. Erase operations will also erase saved pictures.
  - ⚠ 2. Once a picture is erased, it cannot be restored.
  - ⚠ 3. It is not possible to delete only a single sub screen of a 4-frame picture recorded in 16-picture/4-frame mode.
  - ⚠ 4. To erase all of the pictures, change recording mode in the settings. This will erase all of the pictures recorded up to that point. (P12)

**Erase** **Nederlands**

1. Use the play operation to display the picture you wish to erase. (P20)  
Push the SET button and REC button simultaneously for 2 sec. to erase.
  2. The picture to be erased is deleted, and the next picture will be displayed. When the next picture is displayed, let go of the button.
- ⚠ 1. Erase operations will also erase saved pictures.
  - ⚠ 2. Once a picture is erased, it cannot be restored.
  - ⚠ 3. It is not possible to delete only a single sub screen of a 4-frame picture recorded in 16-picture/4-frame mode.
  - ⚠ 4. To erase all of the pictures, change recording mode in the settings. This will erase all of the pictures recorded up to that point. (P12)

**8 SURVEILLANCE SETTING**

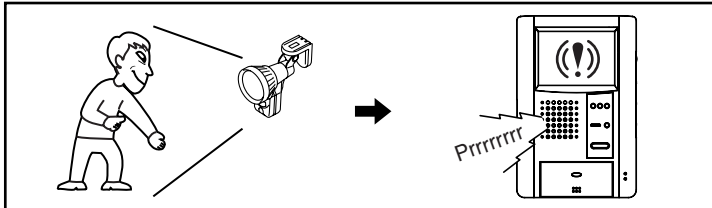

**If a sensor light is installed (local product)** **English**

1. If something is detected by the sensor (locally available product), an alarm goes off with a sound and a warning screen. If more than 1 min. has passed after the absence set (auto absence recording) was set, motion detection will be in operation.
  2. Press the TALK button to restore. (Automatic restoration after approx. 30 sec.)
- NOTES: 1. In step 1, the length of time that the alarm sounds can be changed. (P12)
2. Press the TALK button to stop the alarm and warning screen.
  3. Communication with the sensor light is not possible.
  4. If the absence set (auto absence recording) is cancelled, the sensor light does not call the unit, but the sensor light continues with its surveillance function.

- In calling and communication, sensed alarm does not come out.
- Also the alarm does not come out through Sub room master station(s).

⚠ 1. Read the instruction manual for the sensor light (local product), or contact your local installer or dealer.

**If a sensor light is installed (local product)** **Français**

1. If something is detected by the sensor (locally available product), an alarm goes off with a sound and a warning screen. If more than 1 min. has passed after the absence set (auto absence recording) was set, motion detection will be in operation.
2. Press the TALK button to restore. (Automatic restoration after approx. 30 sec.)

- NOTES: 1. In step 1, the length of time that the alarm sounds can be changed. (P12)
2. Press the TALK button to stop the alarm and warning screen.
  3. Communication with the sensor light is not possible.
  4. If the absence set (auto absence recording) is cancelled, the sensor light does not call the unit, but the sensor light continues with its surveillance function.

- In calling and communication, sensed alarm does not come out.
- Also the alarm does not come out through Sub room master station(s).

⚠ 1. Read the instruction manual for the sensor light (local product), or contact your local installer or dealer.

**If a sensor light is installed (local product)** **Deutsch**

1. If something is detected by the sensor (locally available product), an alarm goes off with a sound and a warning screen. If more than 1 min. has passed after the absence set (auto absence recording) was set, motion detection will be in operation.
2. Press the TALK button to restore. (Automatic restoration after approx. 30 sec.)

- NOTES: 1. In step 1, the length of time that the alarm sounds can be changed. (P12)
2. Press the TALK button to stop the alarm and warning screen.
  3. Communication with the sensor light is not possible.
  4. If the absence set (auto absence recording) is cancelled, the sensor light does not call the unit, but the sensor light continues with its surveillance function.

- In calling and communication, sensed alarm does not come out.
- Also the alarm does not come out through Sub room master station(s).

⚠ 1. Read the instruction manual for the sensor light (local product), or contact your local installer or dealer.

**If a sensor light is installed (local product)** **Español**

1. If something is detected by the sensor (locally available product), an alarm goes off with a sound and a warning screen. If more than 1 min. has passed after the absence set (auto absence recording) was set, motion detection will be in operation.
2. Press the TALK button to restore. (Automatic restoration after approx. 30 sec.)

- NOTES: 1. In step 1, the length of time that the alarm sounds can be changed. (P12)
2. Press the TALK button to stop the alarm and warning screen.
  3. Communication with the sensor light is not possible.
  4. If the absence set (auto absence recording) is cancelled, the sensor light does not call the unit, but the sensor light continues with its surveillance function.

- In calling and communication, sensed alarm does not come out.
- Also the alarm does not come out through Sub room master station(s).

⚠ 1. Read the instruction manual for the sensor light (local product), or contact your local installer or dealer.

**If a sensor light is installed (local product)      Nederlands**

1. If something is detected by the sensor (locally available product), an alarm goes off with a sound and a warning screen. If more than 1 min. has passed after the absence set (auto absence recording) was set, motion detection will be in operation.

2. Press the TALK button to restore. (Automatic restoration after approx. 30 sec.)

NOTES: 1. In step 1, the length of time that the alarm sounds can be changed. (P12)

2. Press the TALK button to stop the alarm and warning screen.

3. Communication with the sensor light is not possible.

4. If the absence set (auto absence recording) is cancelled, the sensor light does not call the unit, but the sensor light continues with its surveillance function.

- In calling and communication, sensed alarm does not come out.

- Also the alarm does not come out through Sub room master station(s).

⚠ 1. Read the instruction manual for the sensor light (local product), or contact your local installer or dealer.

# 9 TECHNICAL PRECAUTIONS TECHNICAL PRECAUTIONS TECHNICAL PRECAUTIONS TECHNICAL PRECAUTIONS

**Technical precautions      English**

- Operating temperature: 0 °C to 40 °C (+32 °F to +104 °F)
- After the unit is not used for a long time or after an extended power failure (approx. 30 min. or more), if both the PLAY and REC buttons light at the same time, perform the record function settings again. (P12)
- The video image may distort when the DOOR RELEASE button is pressed. This is not a unit malfunction.
- Cleaning: Clean the units with a soft cloth dampened with a neutral household cleanser. Do not use an abrasive cleaner or cloth.
- The entrance station is weather-resistant. However, do not spray it directly with high-pressure water. Unit trouble could result.
- If there is a system malfunction, turn the power switch at the master station off and back ON again. If this does not solve the problem, unplug the DC power supply and contact a qualified technician for service.

**Technical precautions      Français**

- Operating temperature: 0 °C to 40 °C (+32 °F to +104 °F)
- After the unit is not used for a long time or after an extended power failure (approx. 30 min. or more), if both the PLAY and REC buttons light at the same time, perform the record function settings again. (P12)
- The video image may distort when the DOOR RELEASE button is pressed. This is not a unit malfunction.
- Cleaning: Clean the units with a soft cloth dampened with a neutral household cleanser. Do not use an abrasive cleaner or cloth.
- The entrance station is weather-resistant. However, do not spray it directly with high-pressure water. Unit trouble could result.
- If there is a system malfunction, turn the power switch at the master station off and back ON again. If this does not solve the problem, unplug the DC power supply and contact a qualified technician for service.

**Technical precautions      Deutsch**

- Operating temperature: 0 °C to 40 °C (+32 °F to +104 °F)
- After the unit is not used for a long time or after an extended power failure (approx. 30 min. or more), if both the PLAY and REC buttons light at the same time, perform the record function settings again. (P12)
- The video image may distort when the DOOR RELEASE button is pressed. This is not a unit malfunction.
- Cleaning: Clean the units with a soft cloth dampened with a neutral household cleanser. Do not use an abrasive cleaner or cloth.
- The entrance station is weather-resistant. However, do not spray it directly with high-pressure water. Unit trouble could result.

- If there is a system malfunction, turn the power switch at the master station off and back ON again. If this does not solve the problem, unplug the DC power supply and contact a qualified technician for service.

**Technical precautions      Español**

- Operating temperature: 0 °C to 40 °C (+32 °F to +104 °F)
- After the unit is not used for a long time or after an extended power failure (approx. 30 min. or more), if both the PLAY and REC buttons light at the same time, perform the record function settings again. (P12)
- The video image may distort when the DOOR RELEASE button is pressed. This is not a unit malfunction.
- Cleaning: Clean the units with a soft cloth dampened with a neutral household cleanser. Do not use an abrasive cleaner or cloth.
- The entrance station is weather-resistant. However, do not spray it directly with high-pressure water. Unit trouble could result.
- If there is a system malfunction, turn the power switch at the master station off and back ON again. If this does not solve the problem, unplug the DC power supply and contact a qualified technician for service.

**Technical precautions      Nederlands**

- Operating temperature: 0 °C to 40 °C (+32 °F to +104 °F)
- After the unit is not used for a long time or after an extended power failure (approx. 30 min. or more), if both the PLAY and REC buttons light at the same time, perform the record function settings again. (P12)
- The video image may distort when the DOOR RELEASE button is pressed. This is not a unit malfunction.
- Cleaning: Clean the units with a soft cloth dampened with a neutral household cleanser. Do not use an abrasive cleaner or cloth.
- The entrance station is weather-resistant. However, do not spray it directly with high-pressure water. Unit trouble could result.
- If there is a system malfunction, turn the power switch at the master station off and back ON again. If this does not solve the problem, unplug the DC power supply and contact a qualified technician for service.

# 10 SPECIFICATIONS SPECIFICATIONS SPECIFICATIONS SPECIFICATIONS

**Specifications      English**

- Power: DC 18V (JB-2MED, JB-2MD, JB-2HD)
- Current consumption: (Max.) 770mA (JB-2MED)  
(Max.) 670 mA (JB-2MD)  
(Max.) 250 mA (JB-2HD).
- Calling: Chime and image, approx. 45 sec.
- Communication: (AUTO) Handsfree  
(MANUAL) Press to talk, release to listen.  
approx. 60sec
- Video monitor: 3-1/2 " direct view TFT color LCD.
- Scanning lines: 525 lines.
- Door release contact: AC 12 V, 0.35 A (dry closure contact L, L).  
(Aiphone's EL-9S is recommended.)
- Dimensions: 175(H) x 115(W) x 43(D) (mm).  
6-7/8 " H x 4-7/32 " W x 1-11/16 " D
- Weight: Approx. 430g (0.95lbs.) (JB-2MED)  
Approx. 400 g (0.9 lbs.) (JB-2MD, JB-2HD)



Specifications	Français
----------------	----------

- Power: DC 18V (JB-2MED, JB-2MD, JB-2HD)
- Current consumption: (Max.) 770mA (JB-2MED)  
(Max.) 670 mA (JB-2MD)  
(Max.) 250 mA (JB-2HD).
- Calling: Chime and image, approx. 45 sec.
- Communication: (AUTO) Handsfree  
(MANUAL) Press to talk, release to listen.  
approx. 60sec
- Video monitor: 3-1/2 " direct view TFT color LCD.
- Scanning lines: 525 lines.
- Door release contact: AC 12 V, 0.35 A (dry closure contact L, L).  
(Aiphone's EL-9S is recommended.)
- Dimensions: 175(H) x 115(W) x 43(D) (mm).  
6-7/8 " H x 4-7/32 " W x 1-11/16 " D
- Weight: Approx. 430g (0.95lbs.) (JB-2MED)  
Approx. 400 g (0.9 lbs.) (JB-2MD, JB-2HD)

Specifications	Deutsch
----------------	---------

- Power: DC 18V (JB-2MED, JB-2MD, JB-2HD)
- Current consumption: (Max.) 770mA (JB-2MED)  
(Max.) 670 mA (JB-2MD)  
(Max.) 250 mA (JB-2HD).
- Calling: Chime and image, approx. 45 sec.
- Communication: (AUTO) Handsfree  
(MANUAL) Press to talk, release to listen.  
approx. 60sec
- Video monitor: 3-1/2 " direct view TFT color LCD.
- Scanning lines: 525 lines.
- Door release contact: AC 12 V, 0.35 A (dry closure contact L, L).  
(Aiphone's EL-9S is recommended.)
- Dimensions: 175(H) x 115(W) x 43(D) (mm).  
6-7/8 " H x 4-7/32 " W x 1-11/16 " D
- Weight: Approx. 430g (0.95lbs.) (JB-2MED)  
Approx. 400 g (0.9 lbs.) (JB-2MD, JB-2HD)

Specifications	Español
----------------	---------

- Power: DC 18V (JB-2MED, JB-2MD, JB-2HD)
- Current consumption: (Max.) 770mA (JB-2MED)  
(Max.) 670 mA (JB-2MD)  
(Max.) 250 mA (JB-2HD).
- Calling: Chime and image, approx. 45 sec.
- Communication: (AUTO) Handsfree  
(MANUAL) Press to talk, release to listen.  
approx. 60sec
- Video monitor: 3-1/2 " direct view TFT color LCD.
- Scanning lines: 525 lines.
- Door release contact: AC 12 V, 0.35 A (dry closure contact L, L).  
(Aiphone's EL-9S is recommended.)
- Dimensions: 175(H) x 115(W) x 43(D) (mm).  
6-7/8 " H x 4-7/32 " W x 1-11/16 " D
- Weight: Approx. 430g (0.95lbs.) (JB-2MED)  
Approx. 400 g (0.9 lbs.) (JB-2MD, JB-2HD)

Specifications	Nederlands
----------------	------------

- Power: DC 18V (JB-2MED, JB-2MD, JB-2HD)
- Current consumption: (Max.) 770mA (JB-2MED)  
(Max.) 670 mA (JB-2MD)  
(Max.) 250 mA (JB-2HD).
- Calling: Chime and image, approx. 45 sec.
- Communication: (AUTO) Handsfree  
(MANUAL) Press to talk, release to listen.  
approx. 60sec
- Video monitor: 3-1/2 " direct view TFT color LCD.
- Scanning lines: 525 lines.
- Door release contact: AC 12 V, 0.35 A (dry closure contact L, L).  
(Aiphone's EL-9S is recommended.)
- Dimensions: 175(H) x 115(W) x 43(D) (mm).  
6-7/8 " H x 4-7/32 " W x 1-11/16 " D
- Weight: Approx. 430g (0.95lbs.) (JB-2MED)  
Approx. 400 g (0.9 lbs.) (JB-2MD, JB-2HD)

## WARRANTY

English

Aiphone warrants its products to be free from defects of material and workmanship under normal use and service for a period of two years after delivery to the ultimate user and will repair free of charge or replace at no charge, should it become defective upon which examination shall disclose to be defective and under warranty. Aiphone reserves unto itself the sole right to make the final decision whether there is a defect in materials and/or workmanship; and whether or not the product is within the warranty. This warranty shall not apply to any Aiphone product which has been subject to misuse, neglect, accident, or to use in violation of instructions furnished, nor extended to units which have been repaired or altered outside of the factory. This warranty does not cover batteries or damage caused by batteries used in connection with the unit. This warranty covers bench repairs only, and any repairs must be made at the shop or place designated in writing by Aiphone. Aiphone will not be responsible for any costs incurred involving on site service calls.

## WARRANTY

Français

Aiphone warrants its products to be free from defects of material and workmanship under normal use and service for a period of two years after delivery to the ultimate user and will repair free of charge or replace at no charge, should it become defective upon which examination shall disclose to be defective and under warranty. Aiphone reserves unto itself the sole right to make the final decision whether there is a defect in materials and/or workmanship; and whether or not the product is within the warranty. This warranty shall not apply to any Aiphone product which has been subject to misuse, neglect, accident, or to use in violation of instructions furnished, nor extended to units which have been repaired or altered outside of the factory. This warranty does not cover batteries or damage caused by batteries used in connection with the unit. This warranty covers bench repairs only, and any repairs must be made at the shop or place designated in writing by Aiphone. Aiphone will not be responsible for any costs incurred involving on site service calls.

## WARRANTY

Deutsch

Aiphone warrants its products to be free from defects of material and workmanship under normal use and service for a period of two years after delivery to the ultimate user and will repair free of charge or replace at no charge, should it become defective upon which examination shall disclose to be defective and under warranty. Aiphone reserves unto itself the sole right to make the final decision whether there is a defect in materials and/or workmanship; and whether or not the product is within the warranty. This warranty shall not apply to any Aiphone product which has been subject to misuse, neglect, accident, or to use in violation of instructions furnished, nor extended to units which have been repaired or altered outside of the factory. This warranty does not cover batteries or damage caused by batteries used in connection with the unit. This warranty covers bench repairs only, and any repairs must be made at the shop or place designated in writing by Aiphone. Aiphone will not be responsible for any costs incurred involving on site service calls.

## WARRANTY

Español

Aiphone warrants its products to be free from defects of material and workmanship under normal use and service for a period of two years after delivery to the ultimate user and will repair free of charge or replace at no charge, should it become defective upon which examination shall disclose to be defective and under warranty. Aiphone reserves unto itself the sole right to make the final decision whether there is a defect in materials and/or workmanship; and whether or not the product is within the warranty. This warranty shall not apply to any Aiphone product which has been subject to misuse, neglect, accident, or to use in violation of instructions furnished, nor extended to units which have been repaired or altered outside of the factory. This warranty does not cover batteries or damage caused by batteries used in connection with the unit. This warranty covers bench repairs only, and any repairs must be made at the shop or place designated in writing by Aiphone. Aiphone will not be responsible for any costs incurred involving on site service calls.

## WARRANTY

Nederlands

Aiphone warrants its products to be free from defects of material and workmanship under normal use and service for a period of two years after delivery to the ultimate user and will repair free of charge or replace at no charge, should it become defective upon which examination shall disclose to be defective and under warranty. Aiphone reserves unto itself the sole right to make the final decision whether there is a defect in materials and/or workmanship; and whether or not the product is within the warranty. This warranty shall not apply to any Aiphone product which has been subject to misuse, neglect, accident, or to use in violation of instructions furnished, nor extended to units which have been repaired or altered outside of the factory. This warranty does not cover batteries or damage caused by batteries used in connection with the unit. This warranty covers bench repairs only, and any repairs must be made at the shop or place designated in writing by Aiphone. Aiphone will not be responsible for any costs incurred involving on site service calls.

This equipment has been tested and found to comply with the limits for a Class B digital device, pursuant to Part 15 of the FCC Rules. These limits are designed to provide reasonable protection against harmful interference in a residential installation. This equipment generates, uses, and can radiate radio frequency energy, and if not installed and used in accordance with the instructions, may cause harmful interference to radio communications. However, there is no guarantee that interference will not occur in a particular installation. If this equipment does cause harmful interference to radio or television reception, which can be determined by turning the equipment off and on, the user is encouraged to try to correct the interference by one or more of the following measures: • Reorient or relocate the receiving antenna. • Connect the equipment into an outlet on a circuit different from that to which the receiver is connected. Increase the separation between the equipment and receiver. • Consult the dealer or an experienced radio/TV technician for help.

 **AIPHONE**®  
*Providing Peace of Mind*  
<http://www.aiphone.com/>

AIPHONE CO., LTD., NAGOYA, JAPAN  
AIPHONE CORPORATION, BELLEVUE, WA, USA  
AIPHONE S.A., WISSOUS, CEDEX, FRANCE

Printed in Japan