

**CLIPSAL**<sup>®</sup>

by **Schneider** Electric



**C-Bus**<sup>®</sup>

**Reflection Range**

**R5060**  
Series



**Installation Instructions**

REGISTERED DESIGN • REGISTERED PATENT

# Contents

<b>1.0 Product Range .....</b>	<b>3</b>
<b>2.0 Description .....</b>	<b>3</b>
<b>3.0 Parts Supplied.....</b>	<b>4</b>
<b>4.0 Installation Instructions.....</b>	<b>4</b>
<b>5.0 Connection to the C-Bus Network .....</b>	<b>7</b>
<b>6.0 Status Indicators .....</b>	<b>7</b>
<b>7.0 C-Bus Power Requirements.....</b>	<b>7</b>
<b>8.0 Power Surges and Short Circuit Conditions .....</b>	<b>8</b>
<b>9.0 Megger Testing.....</b>	<b>8</b>
<b>10.0 Standards Complied.....</b>	<b>8</b>
<b>11.0 Programming Requirements .....</b>	<b>9</b>
<b>12.0 Important Warning.....</b>	<b>9</b>
<b>13.0 Electrical Specifications .....</b>	<b>10</b>
<b>14.0 Mechanical Specifications .....</b>	<b>11</b>
<b>15.0 Further Information .....</b>	<b>12</b>

## 1.0 Product Range

Reflection Series:

<b>R5061NL</b>	1 Gang Key Input Unit, Reflection Series
<b>R5062VNL</b>	2 Gang Key Input Unit, Reflection Series
<b>R5063NL</b>	3 Gang Key Input Unit, Reflection Series
<b>R5064VNL</b>	4 Gang Key Input Unit, Reflection Series
<b>R5066NL</b>	6 Gang Key Input Unit, Reflection Series
<b>R5068NL</b>	8 Gang Key Input Unit, Reflection Series

Reflection Accessories:

<b>R5060WB</b>	Wall Box, Adjustable Height
----------------	-----------------------------

## 2.0 Description

The C-Bus Reflection range of architectural, flat metal style C-Bus Key Input Units are available in a brushed stainless steel finish. The units feature a magnetic mounting mechanism, which ensures that the installed product does not have any visible mounting screws.

Each switch on the plate has an associated blue LED indicator providing feedback status. The Reflection range supports a wide range of functions, such as toggle, on, off, timer, dimmer, remote scene selection, etc. Units may be programmed using the C-Bus Installation Software v2.3.0 (or higher), or via the C-Bus Learn Mode Features.

### NOTE:

A custom wall box is required to mount this switch (catalogue number R5060WB, sold separately). Standard wall brackets and boxes cannot be used. The R5060WB wall box is fully adjustable allowing the Reflection Key Input Units to mount flush with any flat wall surface in a wide variety of building styles.

The Reflection range is not weatherproof, and is therefore not suitable for external/outdoor use.

### 3.0 Parts Supplied

The R5060 C-Bus Reflection Series Key Input Unit and R5060WB Reflection Series Wall Box are sold separately. An exploded view of the Key Input Unit, Wall Box and associated mounting accessories is shown in Figure 3.\*\*

Item No. (see Fig. 3)	Description	Quantity Supplied
1	Wall Box	1
2	Mounting Plate	1
3	Screw 6NC x 10L Csk Hd	4
4	Screw 6NC x 12L	2
5*	Allen Key (3mm Hex Drive)	1
6*	Installation Instruction	1

\* Items not illustrated in exploded view.

\*\*Subject to change without notice.

### 4.0 Installation Instructions

This instruction focuses on the fitting of the R5060 C-Bus Reflection Series Key Input Unit and the adjustments needed to the Wall Box to suit different building types.

The Wall Box may be fitted into suitably prepared masonry or attached to noggins or studs in timber frame buildings. How to fix the Wall Box to the wall is outside the scope of this instruction; standard building practices should be observed.

#### STEP 1

Fix Wall Box to wall (either masonry or timber frame), as shown in Figure 1.

The Mounting Plate is adjustable from 'flush with the Wall Box' to '13mm from the Wall Box'. Always ensure that the Wall Box is within 13mm of finished wall surface.

This completes the installation of the Wall Box.

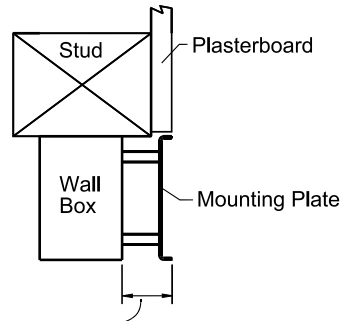

Adjustable Distance, 13mm Max.

**Figure 1.**  
Adjustment Distance as Viewed  
from Above

## STEP 2

Using the Allen Key provided, adjust the four brass mounting screws to set the Mounting Plate distance from the Wall Box, as shown in Figure 2.

Check the distance by seating the Mounting Plate onto the four brass screws.

The top edge of the Mounting Plate should be flush with the wall's finished surface. If the top edge is not flush with the wall, readjust the brass screws until the surfaces are flush.

The suggested approach is to adjust one corner only, fit the Mounting Plate, then adjust the other three corners. Be sure that the Mounting Plate is fitted squarely, and does not rock back and forth in the seated position.

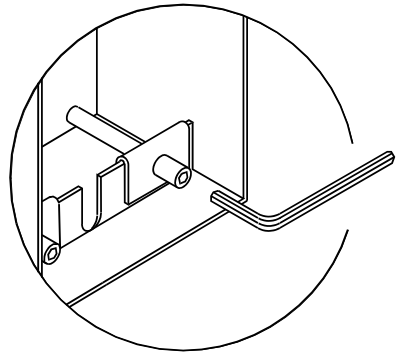

**Figure 2.**  
Adjusting Distance using Allen Key  
Supplied

## STEP 3

Fix the Mounting Plate to the Wall Box using the four 6NC Csk head screws, which screw into the four brass adjusting screws.

## STEP 4

Fix the R5060 Series Key Input Unit to the assembled Wall Box using the two 6NC x 12L screws.

**STEP 5**

'Snap' the stainless steel cover to the Wall Box (the fascia is held magnetically).

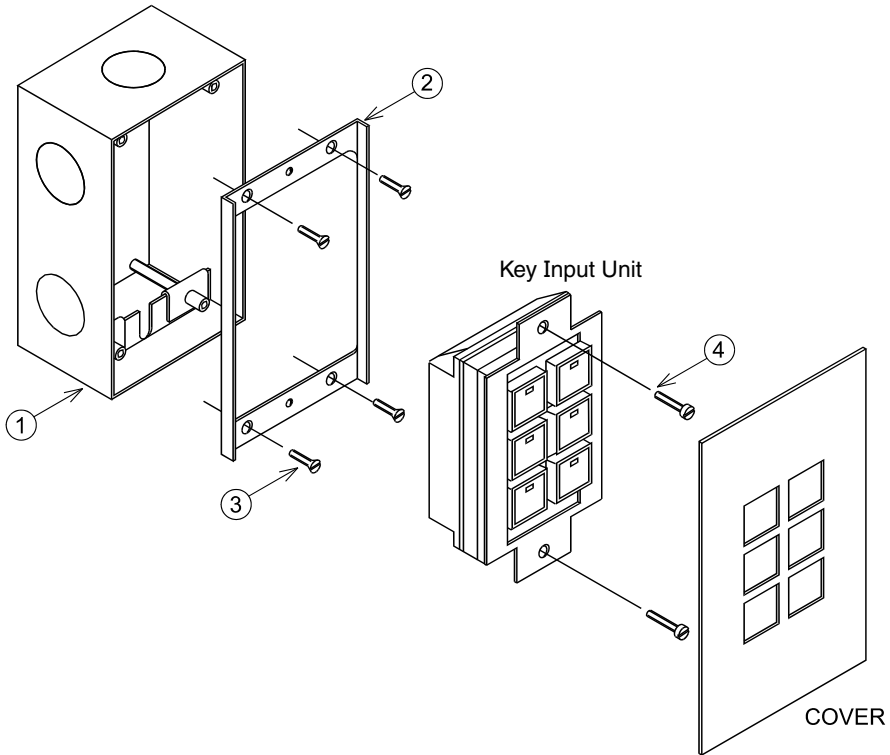

**Figure 3.**

Exploded View of fully assembled R5060WB with Key Input Unit  
(Key Input Unit not supplied with R5060WB)

\* Because of the time lag between fitting the Wall Box and the actual installation of the Key Input Unit it is important to correctly estimate the distance from the top surface of the Wall Box to the finished surface of the wall. Make sure that the adjustment required to flush fit the Reflection switch is within the limit of the Wall Box, which is 13mm.

## 5.0 Connection to the C-Bus Network

Installation requires connection to the unshielded twisted pair C-Bus network cable. It is required that Category 5 data cable is used (Clipsal catalogue number 5005C305B).

RJ Pin	C-Bus Connection	Colour	R5060 Series
1	Remote ON	Green/White	Not Connected
2	Remote ON	Green	Not Connected
3	C-Bus Neg (-)	Orange/White	C-Bus Neg (-)
4	C-Bus Pos (+)	Blue	C-Bus Pos (+)
5	C-Bus Neg (-)	Blue/White	C-Bus Neg (-)
6	C-Bus Pos (+)	Orange	C-Bus Pos (+)
7	Remote OFF	Brown/White	Not Connected
8	Remote OFF	Brown	Not Connected

### NOTE:

The R5060 C-Bus Reflection Series Key Input Units do not have remote override (On/Off) functions, however these connections must be maintained for correct operation of these services across the C-Bus network.

## 6.0 Status Indicators

The R5060 C-Bus Reflection Series Key Input Units incorporate a blue status indicator for each key on the unit. Each is intended to indicate the load (group address) status. The indicator may also be used to indicate key relationships during C-Bus Learn Mode programming operations.

Indicator Status	Meaning
On	Load / group address is on; Indicator is programmed to be always on; Key involved in C-Bus Learn programming operation
Flashing	Timer operation in progress; Key involved in C-Bus Learn programming operation (timer)
Off	Load / group address is off; unit is not powered

## 7.0 C-Bus Power Requirements

The R5060 C-Bus Reflection Series Key Input Unit draws 18mA from the C-Bus network. Adequate C-Bus power supply units must be installed to support the connected devices. If in doubt, consult the C-Bus calculator (Network Design Verification Software Utility) before proceeding with the hardware installation.

## 8.0 Power Surges and Short Circuit Conditions

The R5060 C-Bus Reflection Series Key Input Unit is not directly connected to mains, however the mains voltage that is used to supply power to the C-Bus network must be limited to the range specified. Each Unit incorporates transient protection circuitry and additional external power surge protection devices should be used to enhance system immunity to power surges. It is strongly recommended that overvoltage equipment such as the Clipsal 970 be installed at the switchboard.

## 9.0 Megger Testing

Megger testing must never be performed on the C-Bus data cabling or terminals as it may degrade the performance of the network.

Megger testing the mains wiring of an electrical installation that has C-Bus units connected will not cause any damage to C-Bus units. Since C-Bus units contain electronic components, the installer should interpret megger readings with due regard to the nature of the circuit connection.

## 10.0 Standards Complied

Standard/Directive	Title
AS/NZS1044:1995 Inc A1, A2; IEC/CISPR14-1:1993 Inc A1, A2; EN55014-1: 2000 Inc A1; CISPR14-1:2000 Inc A1	Limits and methods of measurement of radio disturbance characteristics of electrical motor-operated and thermal appliances for household and similar purposes, electric tools and similar electric apparatus
EN61000-3-2:2000; IEC61000-3-2:2000	Electromagnetic Compatibility (EMC) Part 3 Limits Section 2: Limits for Harmonic Current Emissions
EN60669-2-1:2000; IEC60669-2-1:1995 Inc A1, A2	Switches for household and similar fixed electrical installations – particular requirements – Section 1: Electronic switches

### Important Note

- An electrician's licence is not required to install C-Bus Reflection Units.
- Do not connect mains to C-Bus Reflection Units.



## 11.0 Programming Requirements

The R5060 C-Bus Reflection Series Key Input Units must be programmed to set a unique identification (unit address) and the mode of operation on the C-Bus network. C-Bus Installation Software v2.3.0 (or higher) can be used to configure the:

- Project Name
- Part Name
- Unit Address
- Switch Functions.

The C-Bus Installation Software can be downloaded from the Clipsal Integrated Systems Web Site ([www.clipsal.com/cis](http://www.clipsal.com/cis)).

For further information about programming this and other C-Bus units, please refer to the C-Bus Technical Manual (5000S/2, 5000M/2).

The R5060 Reflection Series Key Input Units can also be programmed using C-Bus Learn Mode. For further information about Learn Mode, please consult the C-Bus Learn Mode Operations and Programming Guide.

## 12.0 Important Warning

The use of any non-approved software in conjunction with the hardware installation, without the written consent of Clipsal Australia Pty Ltd, may void any warranties applicable to the hardware.

## 13.0 Electrical Specifications

Catalogue No.	R5060 Series	
C-Bus Supply Voltage	15-36V d.c.	
Current Drawn	18mA	
AC Input Impedance	50k $\Omega$ @ 1kHz	
Electrical Isolation Rating	3.5kV RMS for 1 minute from C-Bus to mains (provided externally to the unit)	
Maximum Number of Units on a Single C-Bus Network	100 Units	
C-Bus Unit Type	KEYA1	R5061NL
	KEYAV2	R5062VNL
	KEYA3	R5063NL
	KEYAV4	R5064VNL
	KEYA6	R5066NL
	KEYA8	R5068NL
Control Functions	Load switching, dimming, timers, remote scene triggering	
Status Indicators	Blue, one indicator per key	
Warm-Up Time	5 seconds	
C-Bus Input Terminals	0.2 – 1.5mm <sup>2</sup> (24-16AWG)	
Shipping Weight	160g 275g	Key unit Wall box
Storage Temperature Range	-10 – 60°C	
Operating Temperature Range	0 – 45°C	
Operating Humidity Range	10 – 95% RH	
Dimensions (L x W x H)	115 x 70 x 31mm 103 x 60 x 40mm	Key unit Wall box

## 14.0 Mechanical Specifications

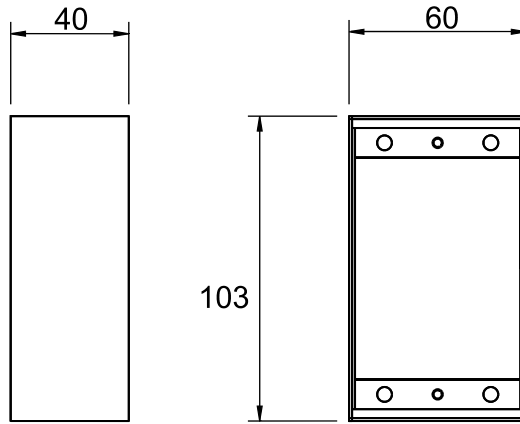

R5060WB Wall Box

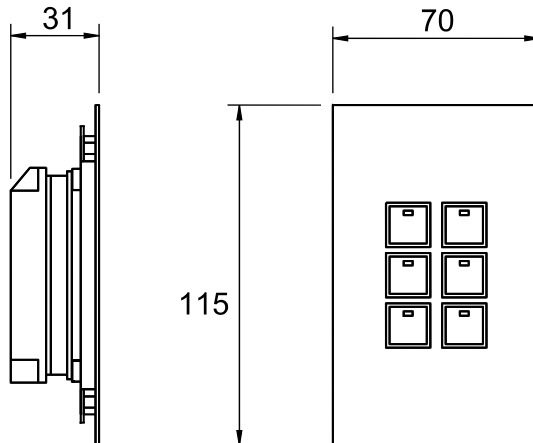

R5060NL Series Key Input Unit

All dimensions are in millimeters.  
No user serviceable parts inside.

## 15.0 Further Information

For further information about configuring this product and other C-Bus devices, please consult the documentation supplied. Further assistance can be obtained as follows:

### C-Bus Manuals

- The 5000M/2 C-Bus Technical Manual provides a comprehensive and definitive guide to Clipsal C-Bus. It includes hardware and software specifications, product datasheets, system design and installation guides, and software overview with fully worked programming examples.

### C-Bus Installation Software

- The 5000S/2 C-Bus Installation Software (includes 5000M/2 C-Bus Technical Manual) may be used to unlock the power and flexibility of Clipsal C-Bus. Unit operation may be completely customised to suit user requirements. Advanced control functions may be programmed.

### C-Bus Installer Training Courses

- Contact your nearest Clipsal Sales or Technical Support Officer and enquire about Clipsal C-Bus Installer Training and Certification Programs today.

### Technical Support and Troubleshooting

- For further assistance, please consult your nearest Clipsal Sales Representative or Technical Support Officer.
- Technical Support Hotline    1300 722 247 (Australia Only)
- Technical Support Email        cis.support@clipsal.com.au

---

#### Clipsal Australia Pty Ltd

A member of Schneider Electric

Contact us: [clipsal.com/feedback](https://clipsal.com/feedback)

National Customer Care Enquiries:

**Tel 1300 2025 25**

**Fax 1300 2025 56**

**clipsal.com**

Clipsal Australia Pty Ltd reserves the right to change specifications, modify designs and discontinue items without incurring obligation and whilst every effort is made to ensure that descriptions, specifications and other information in this catalogue are correct, no warranty is given in respect thereof and the company shall not be liable for any error therein.

© Clipsal Australia Pty Ltd.

Clipsal and C-Bus are registered trademarks of Clipsal Australia Pty Ltd. All other logos and trademarks are the property of their respective owners.