

INSTALLATION INSTRUCTIONS

HIGH-END INDOOR DETECTOR



OPTiMAL series

OPTiMAL series provides a comprehensive product lineup from standard to high-end model which suitable for any applications. In addition to providing high reliable basic performance with our unique infrared detection technology, the combination of active IR and dual technology provides outstanding anti-masking reliability. OPTiMAL series provides compliance with EN50131-1.

- OML-ST** : standard model with PIR (Grade 2)
- OML-AM** : OML-ST with active IR anti-masking method (Grade 3)
- OML-DT** : standard model with PIR and microwave (Grade 2)
- OML-DAM** : OML-DT with active IR anti-masking method (Grade 3)

QUALITY ASSURANCE



N219



1 INSTALLATION HINTS

⚠ Warning	⚠ Warning	⚠ Caution

2 KNOCKOUTS

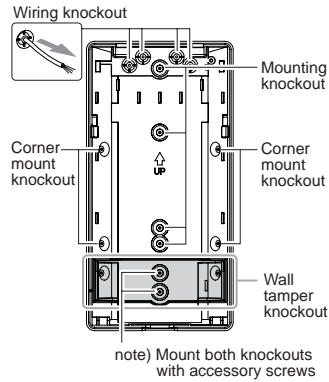

When using a bracket>>
Choose the appropriate mounting holes for corner or wall fixing.

When using a wall tamper>>
Use the knockout for a wall tamper. If the main unit is prised off the wall, the grey section will break away and stay on the wall and the tamper switch will operate. When installing on a plaster board wall or other soft material, pre cut out the grey area from the back plate.

Caution to release the unit base>>

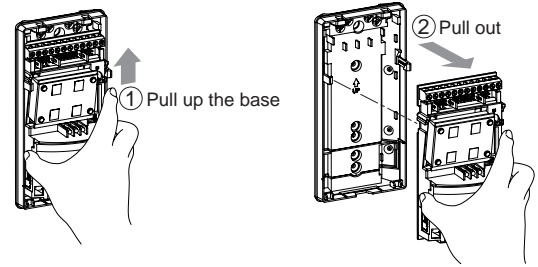

3 DETECTION AREA

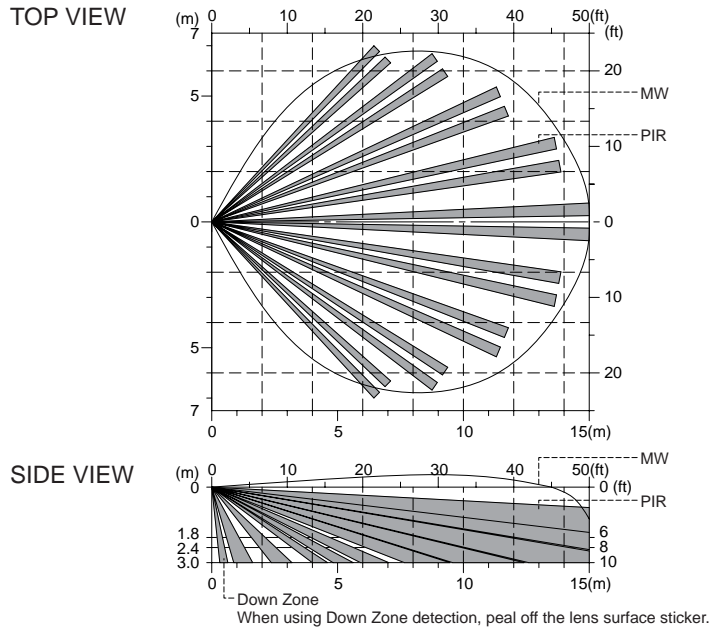

LONG RANGE (when using CL-80N) (OML-ST only)

IMPORTANT>>

- Set the DETECTION MODE switch "STD" position (see 6-B)
- Set the PIR SENSITIVITY "HIGH" with detection range over 20m (67ft.) (see 6-H)

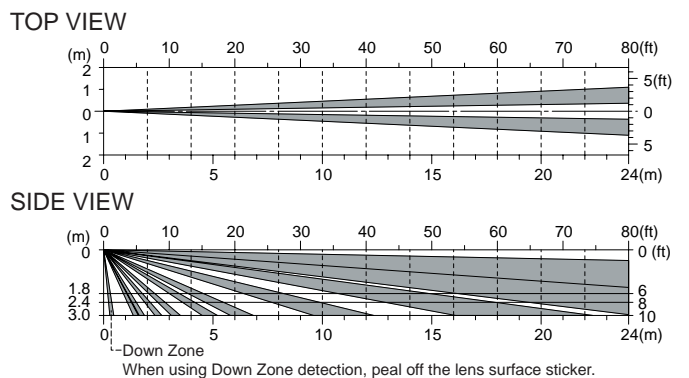

4 WIRING

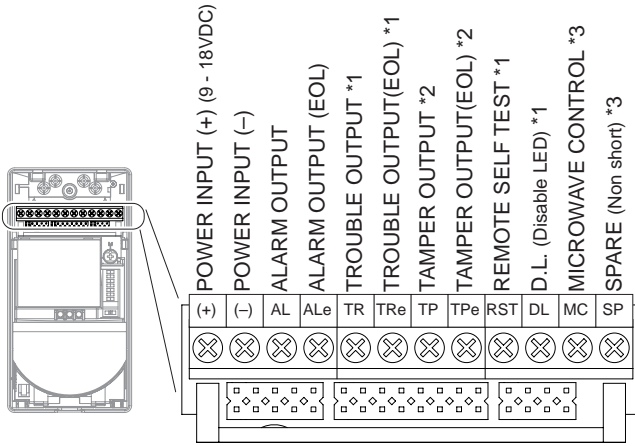

- *1: OML-DAM and OML-AM only
- *2: TP and TPe terminals to be connected to a 24 hour supervisory loop
- *3: OML-DAM, OML-DT and OML-AM
(MC terminal is used as SP terminal for OML-AM)

5 END-OF-LINE (EOL) RESISTORS

5-A When connecting to a control panel that supports the EOL technique

Three types of signals - ALARM OUTPUT, TROUBLE OUTPUT, and TAMPER - can be recognized through the combination of the resistance value and wires for the ALe, TRe, and TPe terminals. Select the ALARM OUTPUT, TROUBLE OUTPUT, and TAMPER resistance values to match the control panel and cover that position with the pin header.

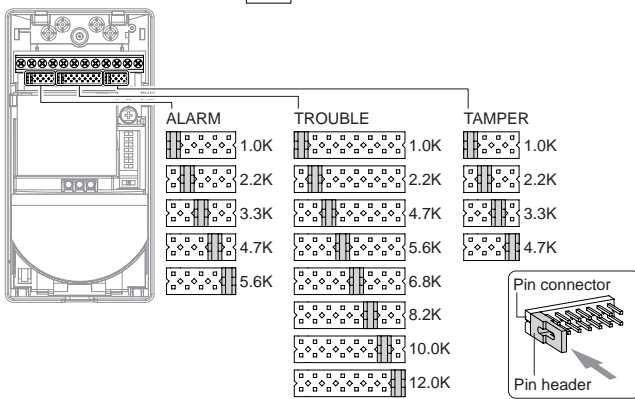
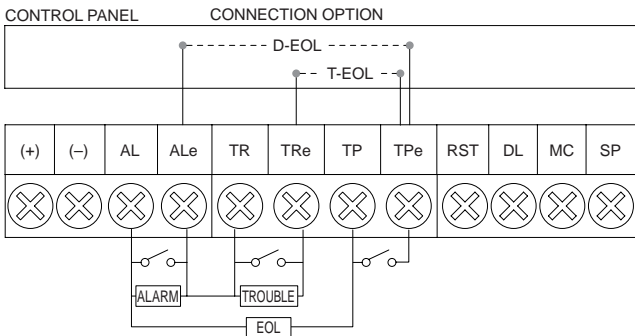

5-B When setting the resistance value without using a pin header

If none of the above resistance values match the control panel, remove the pin header and wire a resistor between the appropriate terminals as follows:

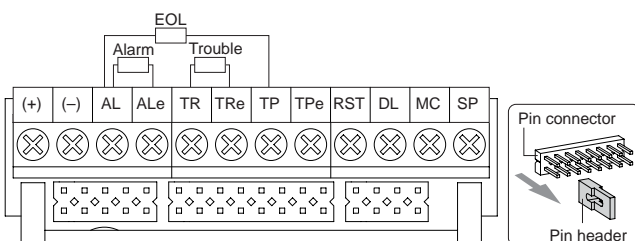

6 DIP SWITCH

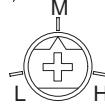
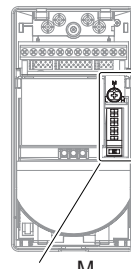

MICROWAVE SENSITIVITY (6-E)

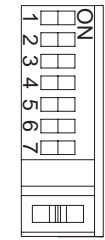

- 1 LED ON/OFF (6-A)
- 2 DETECTION MODE (6-B)
- 3 TROUBLE OUTPUT (6-C)
- 4 ANTI-MASKING SENSITIVITY (6-D)
- 5 MICROWAVE RANGE (6-E)
- 6 POLARITY (6-F)
- 7 MICROWAVE CONTROL (6-G)

PIR SENSITIVITY (6-H)

6-A LED ON/OFF

Dip switch 1

OML-ST OML-AM OML-DT OML-DAM

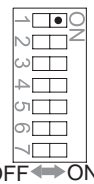

LED can be set "ON" or "OFF".

LED remote control >>

OML-ST OML-AM OML-DT OML-DAM

Also LED can be enabled or disabled remotely from control panel by D.L. terminal. Ensure to set LED switch "OFF" for this setting.

LED enabled	Connect D.L. terminal to common ground (with detector)
LED disabled	No ground to D.L. terminal (open circuit)

6-B DETECTION MODE

Dip switch 2

OML-ST OML-AM OML-DT OML-DAM

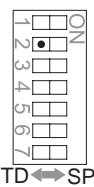

POSITION	FUNCTION
STD (Standard)	For normal applications.
SP (Special)	For use in hostile areas where there may be movement from small animals or other objects such as fax machines or curtains. * Please use this position when applied requirement of EN50131-2-4 6.6.3 (Immunity to microwave signal interference by fluorescent lights.)

6-C TROUBLE OUTPUT

Dip switch 3

OML-ST OML-AM OML-DT OML-DAM

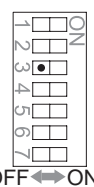

POSITION	OUTPUT TERMINAL
OFF	TROUBLE
ON	TROUBLE and ALARM

* OML-DT has no trouble output. Alarm output is used as trouble signal.

For details on the LED display for a TROUBLE state, see "8.LED FUNCTIONS".

6-D ANTI-MASKING SENSITIVITY Dip switch 4

OML-ST OML-AM OML-DT OML-DAM

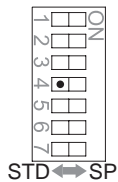

When an object is placed close to the lens surface, for a period of more than 10 seconds then the PIR Anti-Masking circuit will activate and generate a trouble signal. The sensitivity of the anti-masking sensor can be set to STD or SP.

POSITION	FUNCTION
STD (Standard)	Normally set to this.
SP (Special)	Set to this if the sensor malfunctions frequently.

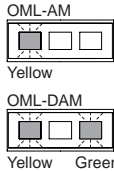

Anti Masking Trouble LED Indication>>
 Yellow blinks (OML-AM).
 Yellow and Green LED's blink (OML-DAM).

Caution>>
 Powering down the detector will reset the trouble output.

6-E MICROWAVE SENSITIVITY / RANGE Dip switch 5 and MW Sensitivity

OML-ST OML-AM OML-DT OML-DAM



The Detection Range changes as follows according to the combination of the MW RANGE and MW Sensitivity.

MW RANGE	MW SENSITIVITY		
	L	M	H
Short	5m (16ft.)	8m (26ft.)	10m (33ft.)
Long	10m (33ft.)	13m (43ft.)	15m (50ft.)

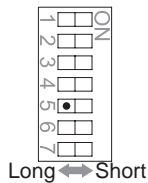

Caution>>
 The above is a guide only.
 Do not set the MW sensitivity too low. This could cause false MW failure.
 It is important to adjust the range and sensitivity so that the MW and PIR detection areas are overlapping.

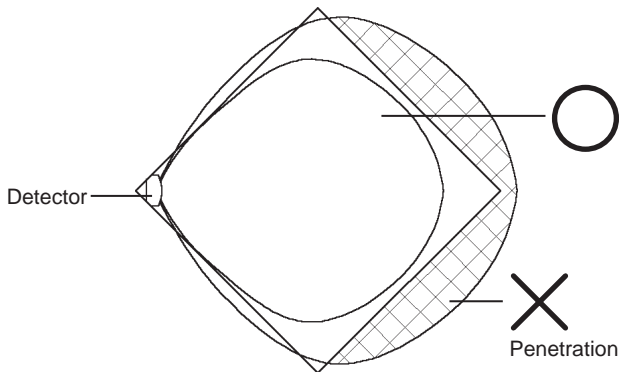

If the microwave detection range is set too wide, it may detect movements outside of the detection area, resulting in false alarms. By creating a microwave detection area to synchronize to the PIR detection area, it achieves higher detection performance and preventing errors and false alarms.

6-F POLARITY Dip switch 6

OML-ST OML-AM OML-DT OML-DAM

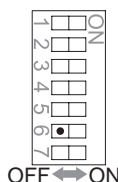

This setting is required only when the MICROWAVE CONTROL is set. (see "6-G. MICROWAVE CONTROL")
 When the system is not armed, the MC Terminal can be used to turn off the MW signal as follows.

POSITION	Input to MC Terminal
ON	NO CONNECTION=MW ON NEGATIVE=MW OFF
OFF	NO CONNECTION=MW OFF NEGATIVE=MW ON

6-G MICROWAVE CONTROL Dip switch 7

OML-ST OML-AM OML-DT OML-DAM

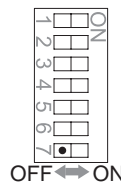

When this switch is set to ON the microwave can be turned ON and OFF from the control panel using the MC terminal.

POSITION	FUNCTION
OFF	Microwave is always transmitted.
ON	Microwave is not transmitted during disarming mode.

* The polarity needs to be set. (see "6-F. POLARITY")

6-H PIR SENSITIVITY PIR SENSITIVITY

OML-ST OML-AM OML-DT OML-DAM

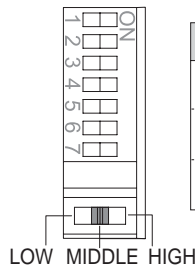

POSITION	FUNCTION
LOW	Suitable for hostile and narrow area
MIDDLE	Suitable for standard applications
HIGH	Suitable for site requires greater sensitivity or long range applications

7 SELF TEST

This function checks the operation of detection ability of PIR and Microwave. This ensures that the unit is always working correctly.

Caution>>
 Powering down the detector will reset the trouble output.

7-A LOCAL SELF TEST

OML-ST OML-AM OML-DT OML-DAM

Local self test is controlled by the detector and runs periodically to test the functionality of the circuitry.

If the local self test fails, the TROUBLE relay is activated and LEDs blink as follows:

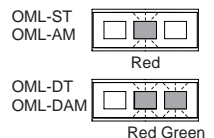

7-B REMOTE SELF TEST

OML-ST OML-AM OML-DT OML-DAM

This test may be initiated by the control panel by applying 0V to the RST terminal. If the remote self test passes, the ALARM relay is activated for 5 seconds.

If the test fails, the TROUBLE Relay is activated and the LEDs will blink (see 7-A).

* This function is available only for PIR part.

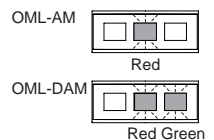

7-C WALK TEST

- Keep at least 1 meter away from the detector and clear of any objects.
- Put the power on after the cover is closed.

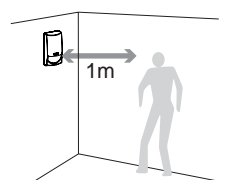

8 LED FUNCTIONS

Yellow Red Green

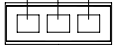

OFF Light Blink

OML-ST	OML-AM	OML-DT	OML-DAM
DETECTOR STATUS	LED Indications	LED operation	
Person detected	Red lights	<input type="checkbox"/> <input type="checkbox"/> <input type="checkbox"/>	
Warm-up period	All LED blink	<input type="checkbox"/> <input type="checkbox"/> <input type="checkbox"/>	
PIR detection	Green lights	<input type="checkbox"/> <input type="checkbox"/> <input type="checkbox"/>	
MW detection	Yellow lights	<input type="checkbox"/> <input type="checkbox"/> <input type="checkbox"/>	
Power supply abnormality	Red blinks	<input type="checkbox"/> <input type="checkbox"/> <input type="checkbox"/>	
Anti-Masking (OML-DAM)	Yellow&green blink	<input type="checkbox"/> <input type="checkbox"/> <input type="checkbox"/>	
Detection failure	Red&green blink	<input type="checkbox"/> <input type="checkbox"/> <input type="checkbox"/>	

OML-ST	OML-AM	OML-DT	OML-DAM
DETECTOR STATUS	LED Indications	LED operation	
Person detected	Red lights	<input type="checkbox"/> <input type="checkbox"/> <input type="checkbox"/>	
Warm-up period	Yellow&red blink	<input type="checkbox"/> <input type="checkbox"/> <input type="checkbox"/>	
Power supply abnormality	Red blinks	<input type="checkbox"/> <input type="checkbox"/> <input type="checkbox"/>	
Anti-Masking	Yellow blinks	<input type="checkbox"/> <input type="checkbox"/> <input type="checkbox"/>	
Detection failure	Red blinks	<input type="checkbox"/> <input type="checkbox"/> <input type="checkbox"/>	

OML-ST	OML-AM	OML-DT	OML-DAM
DETECTOR STATUS	LED Indications	LED operation	
Person detected	Red lights	<input type="checkbox"/> <input type="checkbox"/> <input type="checkbox"/>	
Warm-up period	Red blinks	<input type="checkbox"/> <input type="checkbox"/> <input type="checkbox"/>	
Power supply abnormality	Red blinks	<input type="checkbox"/> <input type="checkbox"/> <input type="checkbox"/>	
Detection failure	Red blinks	<input type="checkbox"/> <input type="checkbox"/> <input type="checkbox"/>	

9 SPECIFICATIONS

Model	OML-ST	OML-AM	OML-DT	OML-DAM
Detection method	Passive infrared		Passive infrared & Microwave	
Detector standard	prEN50131-2-2 (Grade 2)	prEN50131-2-2 (Grade 3)	prEN50131-2-4 (Grade 2)	prEN50131-2-4 (Grade 3)
Masking detection method	-	AIR type	-	AIR type
PIR Coverage [Detection zones]	15m x 15m (50ft. x 50ft.) 85° wide [82 zones]			
Power supply	9 - 18VDC			
Current consumption	16mA (normal) / 18mA (max.) at 12V DC	22mA (normal) / 23mA (max.) at 12V DC	19mA (normal) / 24mA (max.) at 12V DC	25mA (normal) / 29mA (max.) at 12V DC
Alarm output	N.C. 28V DC 0.2A max.			
Tamper switch	N.C. Opens when cover is removed and when the wall tamper switch operates. 28V DC 0.1A max.			
Trouble output	-	N.C. 28V DC 0.2A max.	-	N.C. 28V DC 0.2A max.
Operating temperature	-10°C - +50°C (14°F - 122°F)			
Environmental humidity	95% max.			
RF interference	No alarm 30V/m			
Mounting height	1.8 - 3.0m (6 - 10ft.)	1.8 - 2.4m (6 - 8ft.)		
Weight	180g (6.3oz)			
Dimensions (HxWxD)	140x70x52.3mm (5.51x2.76x2.06 inches)			

* Specifications and design are subject to change without prior notice.

OPTION

- CL-80N : LONG RANGE LENS (OML-ST only)
- FA-1W : Wall Mount Bracket : adjustable $\pm 45^\circ$ (Horizontally), 0-20° (Vertically downwards)
- FA-3 : Compact Wall & Ceiling Bracket : adjustable $\pm 45^\circ$ (Horizontally), 0-10° (Vertically downwards)

NOTE

The following statement will be provided with the equipment as required by Article 6.3 of the R&TTE Directive, 1999/5/EC.

The Optex OPTIMAL series are in conformity with all essential requirements of the R&TTE Directive (1999/5/EC). This equipment has been assessed to the following standards:

EN 300 440: 2004
EN 50130-4: 2004 including amendment 2: 2003
EN 60950: 2006

This product is marked with **CE0560** which signifies conformity with Class II product requirements specified in the R&TTE Directive.

The following table indicates the areas of intended use of the equipment and any known restrictions. For countries not included in this list, please consult the responsible Spectrum Management Agency.

Country of intended use	Restrictions	Country of intended use	Restrictions
Austria	9.900GHz	Luxembourg	10.525GHz
Belgium	10.525GHz	The Netherlands	10.525GHz
Denmark	10.525GHz	Spain	10.525GHz
Finland	9.900GHz	Sweden	10.525GHz
France	9.900GHz	United Kingdom	10.687GHz
Greece	10.525GHz	Other non-EU: Iceland	10.525GHz
Ireland	10.687GHz	Norway	10.525GHz
Italy	9.900GHz	Switzerland	9.900GHz

WARRANTY

5 year replacement warranty

The OPTIMAL series is designed to detect movement of an intruder and activate an alarm control panel.

Being only a part of a complete system, we cannot accept responsibility for any damages or other consequences resulting from an intrusion. Due to our policy of continuous improvement Optex reserves the right to change specification without prior notice.

The Warranty period is from the date of purchase.

FCC Notice:

This equipment has been tested and found to comply with the limits for a field disturbance sensor, pursuant to Part 15 of the FCC Rules. The user is cautioned that changes or modifications not expressly approved by OPTEX could void the user's authority to operate this equipment.

EN50131-1 Grades and Environmental Class:

All models are Environmental Class 2
The OML-ST and OML-DT are Security Grade 2
The OML-AM, OML-DTP and OML-DAM are Security Grade 3



OPTEX CO., LTD. (JAPAN)

(ISO 9001 Certified by LRQA) (ISO 14001 Certified by JET)

5-8-12 Ogoto Otsu Shiga 520-0101 JAPAN

TEL:+81-77-579-8670 FAX:+81-77-579-8190 URL:<http://www.optex.co.jp/e/>

OPTEX INCORPORATED (USA)

TEL:+1-909-993-5770

Tech:(800)566-7839

URL:<http://www.optexamerica.com>

OPTEX SECURITY Sp z o.o. (POLAND)

TEL:+48-22-598-06-55

URL:<http://www.optex.com.pl>

OPTEX (EUROPE) LTD. (UK)

TEL:+44-1628-631000

URL:<http://www.optexeurope.com>

OPTEX KOREA CO., LTD. (KOREA)

TEL:+82-2-719-5971

URL:<http://www.optexkorea.com>

OPTEX SECURITY SAS (FRANCE)

TEL:+33-437-55-50-50

URL:<http://www.optex-security.com>

OPTEX (DONGGUAN) CO., LTD. SHENZHEN OFFICE (CHINA)

TEL:+86-755-33302950

URL:<http://www.optexchina.com>